

MODELS:

| | | | |
|-------------|--------------|--------------|--------------|
| RHEP2S5020N | RHEP2S8030N | RHEP2S15540N | RHEP2S20560N |
| RHEP2S5030N | RHEP2S11530N | RHEP2S15550N | RHEP2S22560N |
| RHEP2S6520N | RHEP2S11540N | RHEP2S18050N | RHEP2S22570N |
| RHEP2S6530N | RHEP2S13030N | RHEP2S18060N | RHEP2S25060N |
| RHEP2S8020N | RHEP2S13040N | RHEP2S20550N | RHEP2S25070N |

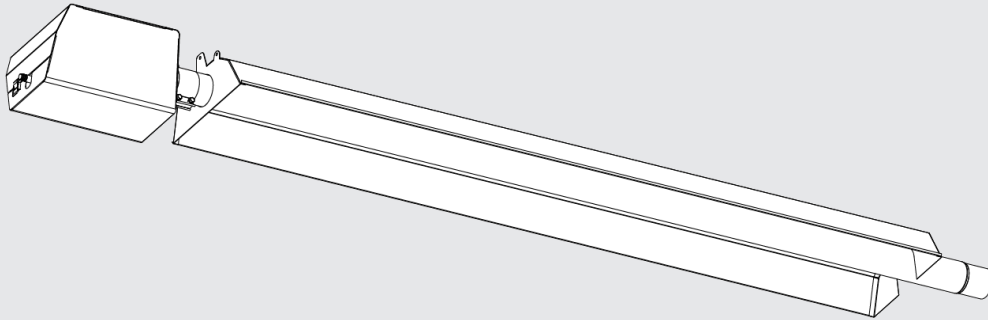

High-Efficiency (HE+) Series Infrared Gas Heater 2-Stage Supplemental Manual

Rinnai®

**LOW INTENSITY TUBE TYPE INFRARED HEATER
WITH HIGH EFFICIENCY EC Motor**

ANSI Z83.20-2016 • CSA 2.34-2016

NOTICE:

This manual is current and correct for this product at time of manufacture. Occasional revision of the product Certification Standard may require changes to the product and/or this manual. This publication, or parts thereof, may not be reproduced in any form, without prior written consent from Rinnai. Unauthorized use or distribution of this publication is strictly prohibited.



TWO STAGE — SUPPLEMENTARY MANUAL
A GENERAL INFORMATION MANUAL IS INCLUDED IN THE BURNER KIT



WARNING Improper installation, adjustment, alteration, service or maintenance can cause property damage, injury or death. Read the installation, operating and maintenance instructions thoroughly before installing or servicing this heater.



SAFETY ALERT:

Do not store or use gasoline or other flammable vapours and liquids in the vicinity of this or any other gas fired appliance.



IF YOU SMELL GAS:

- Extinguish any open flame
- Do not attempt to light this or any other appliance
- Don't touch any electrical switch, or telephone
- Immediately call your gas supplier from a neighbor's phone
- Follow any and all instruction from your gas supplier
- If your gas supplier is not available, call the fire department



FIELD CONVERTIBILITY:

This appliance is field convertible to LP gas.
Only use a kit available from Rinnai.
Follow instructions provided in the kit and all local and national codes.

Keep this manual in a secure place.

Record for future reference:

Model #: _____

Serial #: _____

HE+ SERIES: TWO-STAGE MODELS

- ALSO REFER TO THE GENERAL MANUAL INCLUDED FOR THIS SERIES HEATER

| <u>THIS SUPPLEMENTARY MANUAL: TABLE OF CONTENTS</u> | | | |
|--|------------|--------------------------------------|-----------|
| TOPIC | PAGE | TOPIC |PAGE |
| APPLICATION | 4 | 8B. WIRING DIAGRAM: MULTIPLE | |
| 1. INPUT RATINGS AND DIMENSIONS | 5 | HEATERS PER THERMOSTAT | 22 |
| 2. BURNER / TUBE KIT ASSEMBLY CHART | 7 | 9. FENWAL DSI: SEQUENCE OF OPERATION | 23 |
| 3. TURBULATOR LENGTH & LOCATION | 11 | SPARK IGNITER SET UP | 25 |
| 4. COMBUSTION AIR DUCTING | 13 | FENWAL DSI SERVICE CHECK | 25 |
| 5. FLUE VENTING: | 14 | 10. TROUBLESHOOTING GUIDE: DSI | 26 |
| MIN./MAX. SYSTEM LENGTHS | 15 | 11. TROUBLESHOOTING GUIDE: HEATER | 27 |
| HEATER EXPANSION & VENT | 16 | 12. START- UP / COMMISSIONING SHEET | 29 |
| VERTICAL VENTING—CATEGORY I | 17 | 13. GAS CONVERSION OF BURNER | 31 |
| HORIZONTAL VENTING—CATEGORY III | 18 | 14. HIGH ALTITUDE & ORIFICE CHART | 32 - 33 |
| 6. GAS SUPPLY PRESSURES | 20 | 15. BURNER PARTS LIST | 34 |
| 7. ELECTRICAL AND THERMOSTAT | 20 | 16. TUBE SYSTEM PARTS LIST | 36 |
| 8A. WIRING DIAGRAM: FENWAL DSI | | | |
| 24V or 120V THERMOSTAT | 21 | | |

| <u>GENERAL MANUAL: TABLE OF CONTENTS</u> | | | |
|---|------------|-----------------------------------|-----------|
| TOPIC | PAGE | TOPIC |PAGE |
|  IMPORTANT INFORMATION - READ FIRST | | 7. SYSTEMS WITH 90° & 180° ELBOWS | 12 |
| APPLICATION | 4 | ELBOW KIT DIMENSIONS | 13 |
| HEATER EXPANSION | 5, 31 | 8. SUSPENSION OF THE SYSTEM | 14 |
| GAS CONNECTION | 5, 31 | 9. BURNER & TUBE INSTALLATION: | |
| VENTING | 5, 26 | STRAIGHT TUBE SYSTEM | 15 |
| START UP 'SMOKE' | 5 | SPECIAL COUPLING - 180 to 260 Mbh | 18 |
| THERMOSTAT SETTING / COMFORT | 5 | 10. SEISMIC RESTRAINT | 19 |
| TUBE 'GLOW' | 6 | HIGH WIND RESTRAINT | 19 |
| CLEARANCE TO COMBUSTIBLES | 6 | 11. REFLECTOR INSTALLATION | 20 |
| Clearances Figure & Table | 7 | 12. GAS SUPPLY | 21 |
| STACKING HEIGHT SIGN | 8 | HEATER EXPANSION | 22 |
| | | FLEXIBLE GAS CONNECTION | 23 |
| 1. LABOR REQUIREMENTS | 9 | 13. ELECTRICAL AND THERMOSTAT | 24 |
| 2. INSTALLATION IN AIRCRAFT HANGARS | 9 | 14. HIGH ALTITUDE INSTALLATION | 24 |
| 3. COMMERCIAL GARAGES | 9 | 15. LIGHTING INSTRUCTIONS | 24 |
| 4. USE OTHER THAN SPACE HEATING | 9 | 16. RECOMMENDED MAINTENANCE | 24 |
| 5. PRE-INSTALLATION SURVEY | 10 | 17. OPTIONAL ACCESSORIES | 25 |
| 6. MOUNTING CLEARANCES | 11 | OPTIONAL CONTROLS | 27 |
| SERVICE CLEARANCE | 11 | WARRANTY STATEMENT | BACK PAGE |
| HEATER PLACEMENT GUIDELINES | 12 | | |



WARNING



Improper installation, adjustment, alteration, service or maintenance can cause property damage, injury or death. Read and understand this installation and operation manual thoroughly prior to assembly, installation, operation or service to this appliance.

This heater must be installed and serviced only by a trained gas service technician.



Do not store or use gasoline or other flammable vapours and liquids in the vicinity of this or any other gas fired appliance.

Failure to comply could result in personal injury, death, fire and/or property damage.



Do not store or use gasoline or other flammable vapours and liquids in the vicinity of this or any other gas fired appliance.

This appliance may have sharp edges and corners. Wear protective clothing such as gloves and protective eye wear when servicing this or any other appliance.

California Proposition 65:



WARNING: This product can expose you to chemicals including carbon monoxide, which is known to the State of California to cause birth defects or other reproductive harm. For more information, go to www.P65Warnings.ca.gov

APPLICATION

HE+ Series models are two-stage gas-fired radiant tube heaters that may be installed for heating of commercial / industrial indoor spaces. Not for use in residential dwellings.

A “residential dwelling” is defined in the standard as “a housekeeping unit used or intended to be used as a domicile by one or more persons, containing cooking, eating, living, sleeping, and/or sanitary facilities. A residential dwelling does not include an attached garage, detached garage, workshop or outdoors”. Local Code requirements take precedence for this application.

It is beyond the scope of these instructions to consider all conditions and requirements that may be encountered in the field. Installation must conform with all local codes or, in the absence of local codes, with the latest edition of the National Fuel Gas Code, ANSI Z223.1/NFPA 54 in the U.S.A. The latest edition Electrical Code ANSI/NFPA No. 70 in the U.S.A. must also be observed.

Installation of a gas fired tube heater must conform to all heating installation design procedures including clearance to combustibles, connection to the gas and electrical supplies, and ventilation requirements.

This heater is not for installation in a Class 1 or Class 2 explosive environment, nor in a residential dwelling. If installation of this equipment is in question, consult with the local authority having jurisdiction (Fire Marshall, labor department, insurance underwriter, or other).

Revisions to codes and/or standards, may require revision to equipment and installation procedures. In case of discrepancy, the latest codes, standards, and installation manual will take priority over prior releases.

1. TABLE 1: INPUT RATINGS (BTUH) AND DIMENSIONS

| TWO-STAGE INPUT RATE [BTUH] | FUEL TYPE | TUBE LENGTH STRAIGHT [FT] | OVERALL HEATER LENGTH [FT] | APPROX NET WEIGHT [LB] |
|-----------------------------|--------------|---------------------------|----------------------------|------------------------|
| 50,000 | NG / PROPANE | 20 | 21' 7" | 111 |
| | | 30 | 31' 3" | 154 |
| 65,000 | NG / PROPANE | 20 | 21' 7" | 111 |
| | | 30 | 31' 3" | 154 |
| 80,000 | NG / PROPANE | 20 | 21' 7" | 111 |
| | | 30 | 31' 3" | 154 |
| 115,000 | NG / PROPANE | 30 | 31' 3" | 154 |
| | | 40 | 40' 11" | 197 |
| 130,000 | NG / PROPANE | 30 | 31' 3" | 154 |
| | | 40 | 40' 11" | 197 |
| 155,000 | NG / PROPANE | 40 | 40' 11" | 197 |
| | | 50 | 50' 7" | 239 |
| 180,000 | NG / PROPANE | 50 | 50' 7" | 239 |
| | | 60 | 60' 3" | 282 |
| 205,000 | NG / PROPANE | 50 | 50' 7" | 239 |
| | | 60 | 60' 3" | 282 |
| 225,000 | NG / PROPANE | 60 | 60' 3" | 282 |
| | | 70 | 69' 11" | 324 |
| 250,000 | NG / PROPANE | 60 | 60' 3" | 282 |
| | | 70 | 69' 11" | 324 |

FLEXIBLE GAS CONNECTOR (Included in Burner Kit) - MUST INSTALL - see GENERAL MANUAL Section 15

USA - Stainless Steel Flexible Gas Connector

205,000 or less:
 903000013 - 1/2"x24"
 225,000 or more:
 903000061 - 3/4"x36"

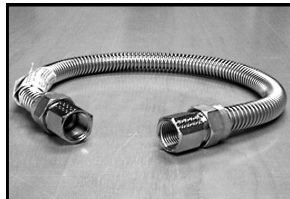

FIGURE 1 HEATER DIMENSIONS

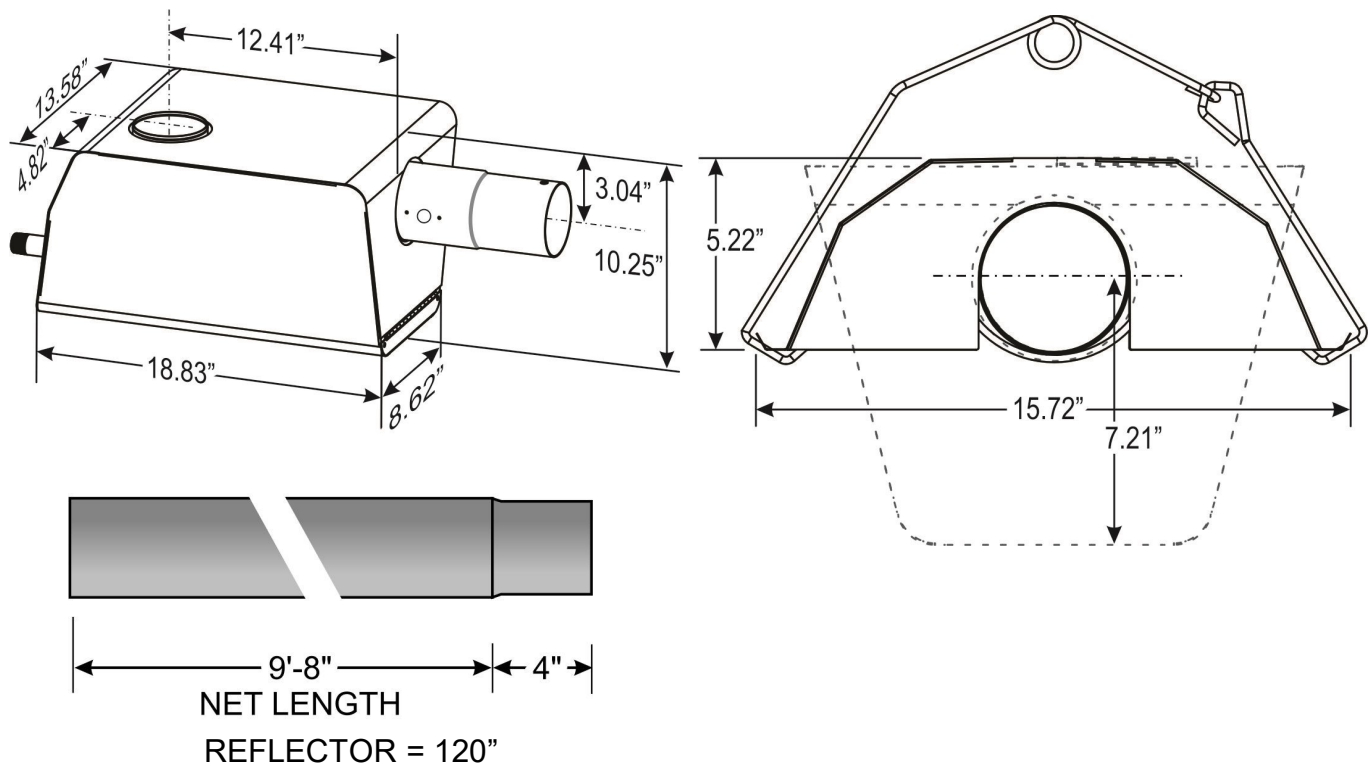
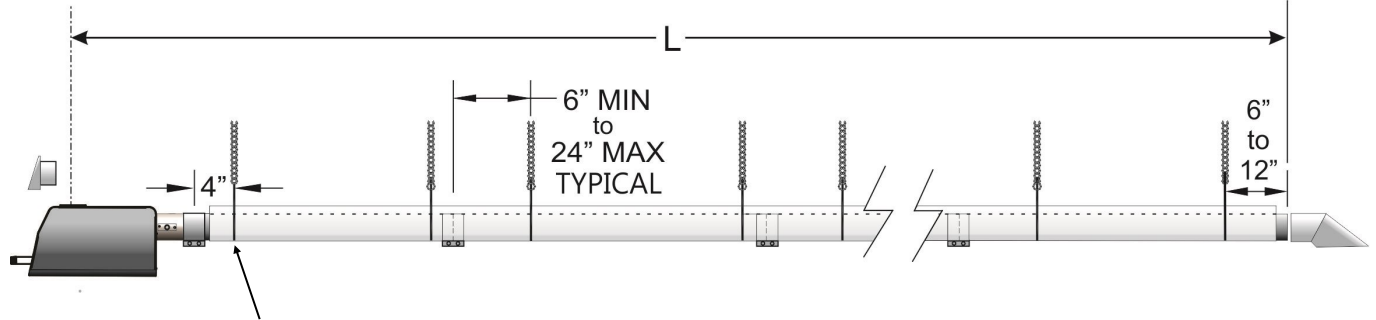

FIGURE 2 HANGER SPACING / LENGTH - AIR INTAKE TO VENT END



- POSITION BURNER END HANGER 4 INCHES (10 CM) FROM BURNER CONNECTION
- LOCATE SYSTEM HANGERS NO LESS THAN 6 INCHES (150mm) AND NO MORE THAN 24 INCHES (610mm) FROM TUBE COUPLING

| <u>Tube Length</u> | <u>'L' = center air intake to end</u> | | | <u>Tube Length</u> | <u>'L' = center air intake to end</u> | | |
|--------------------|---------------------------------------|------------|-----------|--------------------|---------------------------------------|------------|-----------|
| 10' | 11'-3 3/4" | ; 135 3/4" | ; 345 cm | 50' | 49'-11 3/4" | ; 599 3/4" | ; 1523 cm |
| 20' | 20'-11 3/4" | ; 251 3/4" | ; 628 cm | 60' | 59'-7 3/4" | ; 715 3/4" | ; 1818 cm |
| 30' | 30'-7 3/4" | ; 367 3/4" | ; 934 cm | 70' | 69'-3 3/4" | ; 831 3/4" | ; 2113 cm |
| 40' | 40'-3 3/4" | ; 483 3/4" | ; 1229 cm | | | | |

2. TABLE 2: HE+ SERIES TUBE KIT ASSEMBLY CHART



BEFORE INSTALLING: ENSURE you have the CORRECT TUBE KIT(s) for the BURNER INPUT

| INPUT [BTUH] | TUBE LENGTH | BASE SYSTEM TUBE KIT(S) | | FIRST TUBE | SECOND TUBE |
|--------------|-------------|-------------------------|---------------|------------------|------------------|
| | | PRIMARY KIT | SECONDARY KIT | | |
| 50,000 | 20 | RHEPP2AH | N/A | Aluminized Steel | Hot Rolled Steel |
| 50,000 | 30 | RHEPP3AH | N/A | Aluminized Steel | Hot Rolled Steel |
| 65,000 | 20 | RHEPP2AH | N/A | Aluminized Steel | Hot Rolled Steel |
| 65,000 | 30 | RHEPP3AH | N/A | Aluminized Steel | Hot Rolled Steel |
| 80,000 | 20 | RHEPP2AH | N/A | Aluminized Steel | Hot Rolled Steel |
| 80,000 | 30 | RHEPP3AH | N/A | Aluminized Steel | Hot Rolled Steel |
| 115,000 | 30 | RHEPP3AH | N/A | Aluminized Steel | Hot Rolled Steel |
| 115,000 | 40 | RHEPP4AH | N/A | Aluminized Steel | Hot Rolled Steel |
| 130,000 | 30 | RHEPP3AH | N/A | Aluminized Steel | Hot Rolled Steel |
| 130,000 | 40 | RHEPP4AH | N/A | Aluminized Steel | Hot Rolled Steel |
| 155,000 | 40 | RHEPP4AH | N/A | Aluminized Steel | Hot Rolled Steel |
| 155,000 | 50 | RHEPP3AH | RHEPS2HHS1S2 | Aluminized Steel | Hot Rolled Steel |
| 180,000 | 50 | RHEPP3AH | RHEPS2HHS1S2 | Aluminized Steel | Hot Rolled Steel |
| 180,000 | 60 | RHEPP3AH | RHEPS3HHS1S2 | Aluminized Steel | Hot Rolled Steel |
| 205,000 | 50 | RHEPP3AH | RHEPS2HHS1S2 | Aluminized Steel | Hot Rolled Steel |
| 205,000 | 60 | RHEPP3AH | RHEPS3HHS1S2 | Aluminized Steel | Hot Rolled Steel |
| 225,000 | 60 | RHEPP4SS | RHEPS2HHS1S2 | Stainless Steel | Stainless Steel |
| 225,000 | 70 | RHEPP4SS | RHEPS3HHS1S2 | Stainless Steel | Stainless Steel |
| 250,000 | 60 | RHEPP4SS | RHEPS2HHS1S2 | Stainless Steel | Stainless Steel |
| 250,000 | 70 | RHEPP4SS | RHEPS3HHS1S2 | Stainless Steel | Stainless Steel |

TWO STAGE TUBE KIT SYSTEMS: INPUTS 50,000 TO 155,000 BTUH
SYSTEMS FOR INPUTS 180,000 TO 250,000: NEXT PAGE

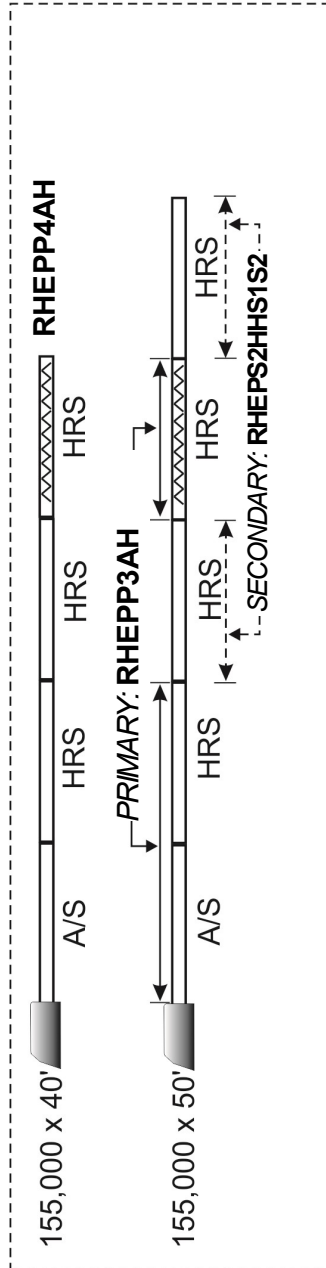
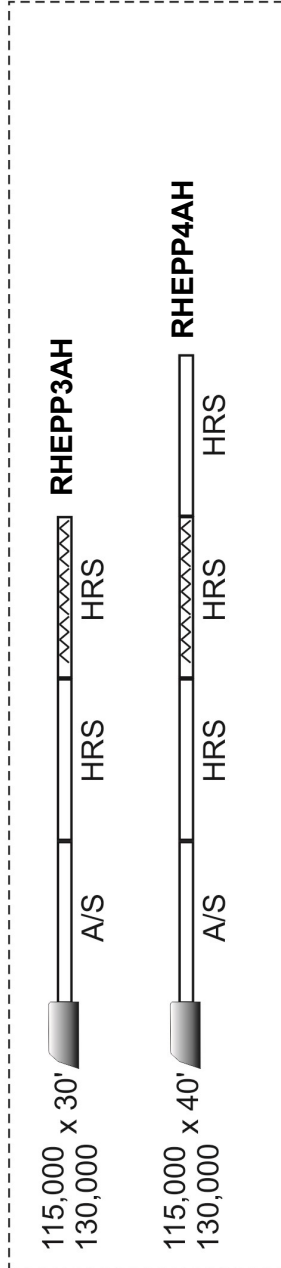
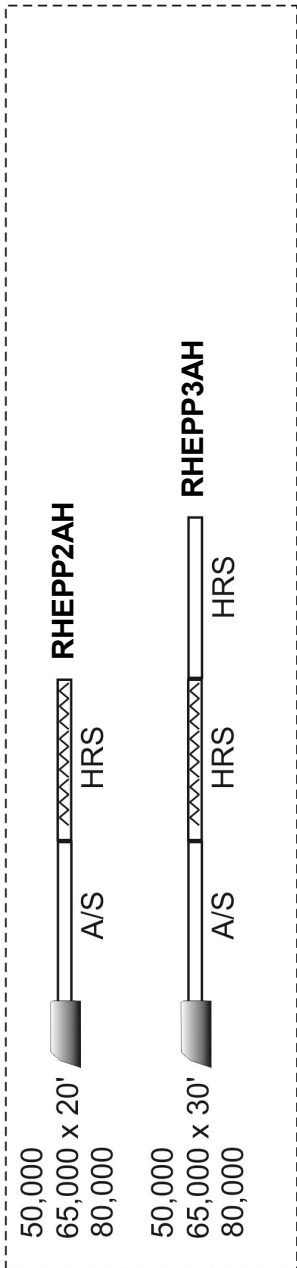

MATERIALS LEGEND:

- A/S = ALUMINIZED STEEL TUBE
- HRS = HOT ROLLED STEEL TUBE
- S/S = STAINLESS STEEL TUBE
- ^^ = TURBULATOR 2.25" x 36"

TUBE KIT NOMENCLATURE

Example: **R - HEP - P - 2 - A - H - 1S2S**

| | |
|-------------|--|
| R | Rinnai |
| HEP | Series: High Efficiency Plus/Comfort |
| P | Type: <ul style="list-style-type: none"> • P = Primary • S = Secondary |
| 2 | Tube Quantity (1-4) |
| A | First Tube Material: <ul style="list-style-type: none"> • A = Aluminum • H = Hot Rolled Steel • S = Stainless Steel |
| H | Second Tube Material: <ul style="list-style-type: none"> • A = Aluminum • H = Hot Rolled Steel • S = Stainless Steel |
| 1S2S | Stage <ul style="list-style-type: none"> • M = Modulating • MX = Modulating Alternate Turbulator • 1S2S = 1 and 2 Stage |

TWO STAGE TUBE KIT SYSTEMS: INPUTS 180,000 TO 250,000 BTUH

SYSTEMS FOR INPUTS 50,000 TO 155,000: PREVIOUS PAGE

MATERIALS LEGEND:

A/S = ALUMINIZED STEEL TUBE
 HRS = HOT ROLLED STEEL TUBE
 S/S = STAINLESS STEEL TUBE

^^ = TURBULATOR 2.25" x 36"

NOTE:
 For 180 & 205 MBH models, one 36" turbulator should be removed from the tube kit. Please see next page for the turbulator removal instructions.

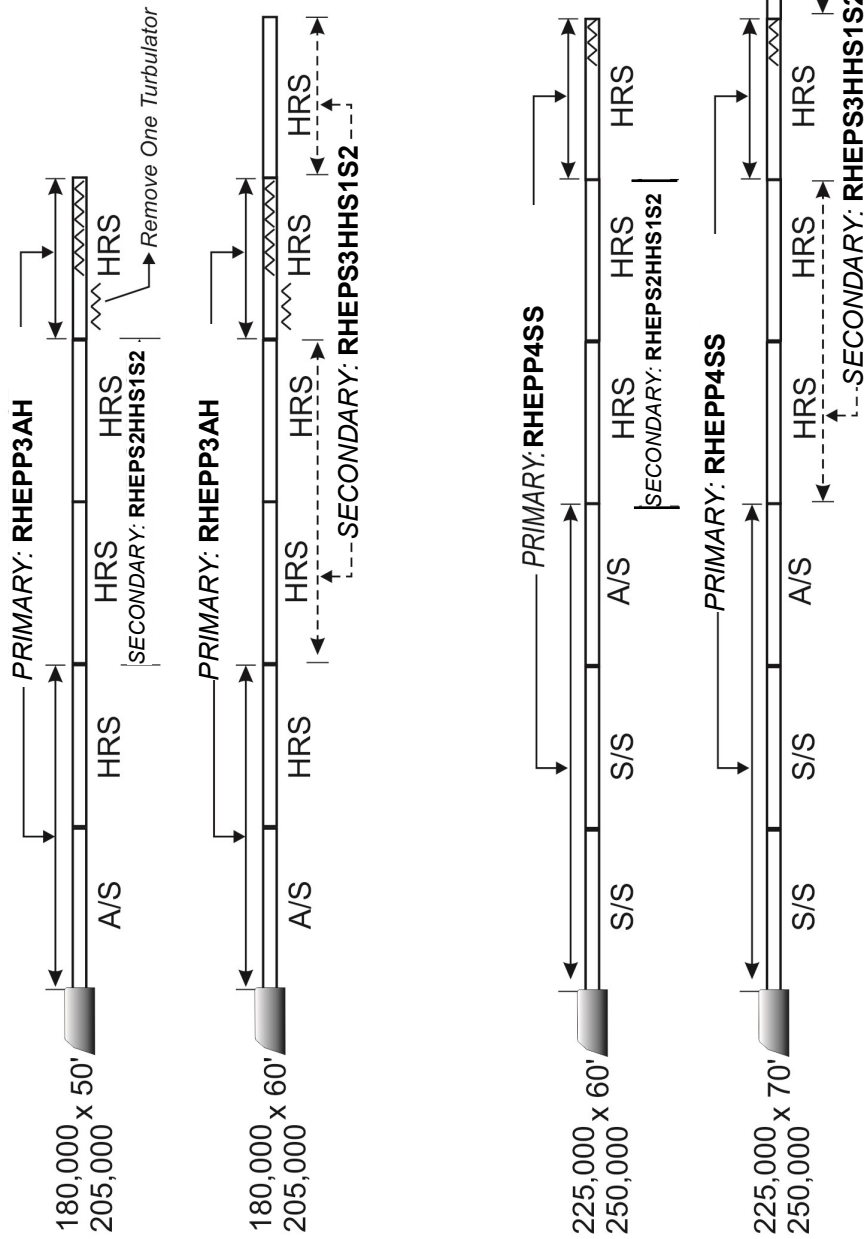

**This Page Intentionally
Left Blank**

3. TURBULATOR LENGTHS & LOCATION IN SYSTEM



NOTE: Improper location of a turbulator can cause malfunction of the heater, property damage, and will void the heater warranty.

Tubes with turbulators inside are clearly labeled for easy identification.

ALL turbulators are located within the BASE LENGTH (shortest length) of the tube system. One or two tubes added to system base length are regular empty tubes with no turbulators. Each turbulator is 36 inches in length by 2.25" width (see Table below).

Turbulators link together with tabs, and individual sections can be removed by straightening tabs (see below). A Base Tube Kit may need turbulator removal depending on input rate (see below and illustration next page).

The orientation of the turbulator(s) [up - down; sideways] in the tube does not matter.

TABLE 3: TURBULATORS: QUANTITY AND LOCATION IN TUBE SYSTEM

| FUEL TYPE | MODEL Input x Base Length (FT) | TURBULATOR [QUANTITY] x WIDTH x LENGTH | TURBULATOR LOCATION IN BASE LENGTH | INSTALLER ACTION REQUIRED: REMOVE & DISCARD TURBULATOR SECTION |
|-----------|--------------------------------|--|------------------------------------|--|
| NG or LP | 50,000 x 20 | [3] x 2.25" x 36" | 3 IN 2nd TUBE | No action required |
| NG or LP | 65,000 x 20 | [3] x 2.25" x 36" | 3 IN 2nd TUBE | No action required |
| NG or LP | 80,000 x 20 | [3] x 2.25" x 36" | 3 IN 2nd TUBE | No action required |
| NG or LP | 115,000 x 30 | [3] x 2.25" x 36" | 3 IN 3rd TUBE | No action required |
| NG or LP | 130,000 x 30 | [3] x 2.25" x 36" | 3 IN 3rd TUBE | No action required |
| NG or LP | 155,000 x 40 | [3] x 2.25" x 36" | 3 IN 4th TUBE | No action required |
| NG or LP | 180,000 x 50 | [2] x 2.25" x 36" | 2 IN 5th TUBE | Remove 1 turbulator from 5th tube |
| NG or LP | 205,000 x 50 | [2] x 2.25" x 36" | 2 IN 5th TUBE | Remove 1 turbulator from 5th tube |
| NG or LP | 225,000 x 60 | [1] x 2.25" x 36" | 1 IN 6th TUBE | No action required |
| NG or LP | 250,000 x 60 | [1] x 2.25" x 36" | 1 IN 6th TUBE | No action required |

TURBULATOR SECTION REMOVAL: Models: 180,000 & 205,000 BTUH

1. Carefully pull out the turbulator section to be removed from the swaged end of the tube. The end of the turbulator to be left inside the tube should not extend beyond the swaged portion of the tube. Rotate the tube to have access to the locking tab

2. Bend and push the outer tab with pliers until it is in the vertical position

3. Lift up the end of the turbulator that is left inside the tube to disengage the tab that was bent in the vertical position

4. While still holding the inner turbulator in its location, pull the outer turbulator to completely disengage and discard

FIGURE 3



TURBULATORS: LOCATION IN BASE SYSTEM TUBE KITS

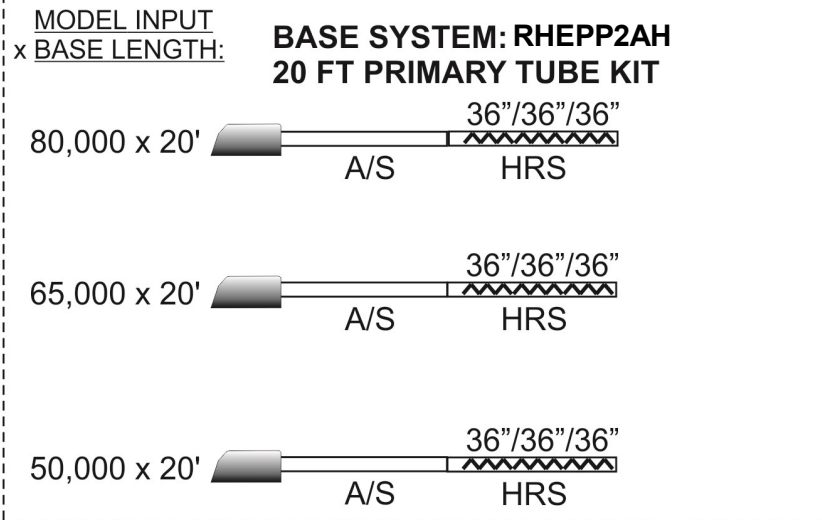

MATERIALS LEGEND:

A/S = ALUMINIZED STEEL TUBE
HRS = HOT ROLLED STEEL TUBE
S/S = STAINLESS STEEL TUBE

~ = TURBULATOR 2.25" x 36"

NOTE:

Turbulators are located within the 'Base Length' of the system. Secondary tube kits can be added to increase system length. Refer to Tube Kit section.

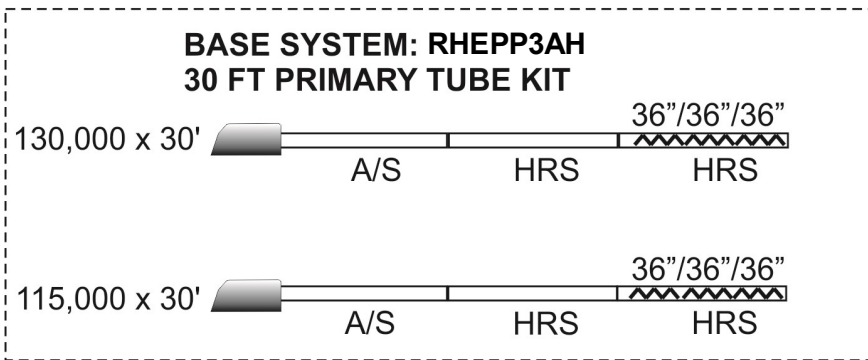

BASE SYSTEM: RHEPP4AH: 40 FT PRIMARY TUBE KIT

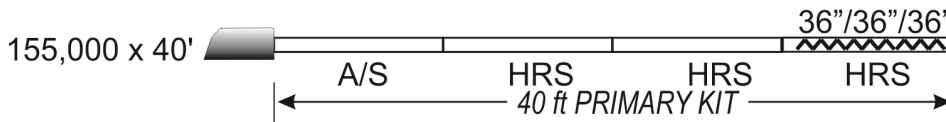

BASE SYSTEM: RHEPP3AH + RHEPS2HHS1S2

30 FT PRIMARY + 20 FT SECONDARY TUBE KIT

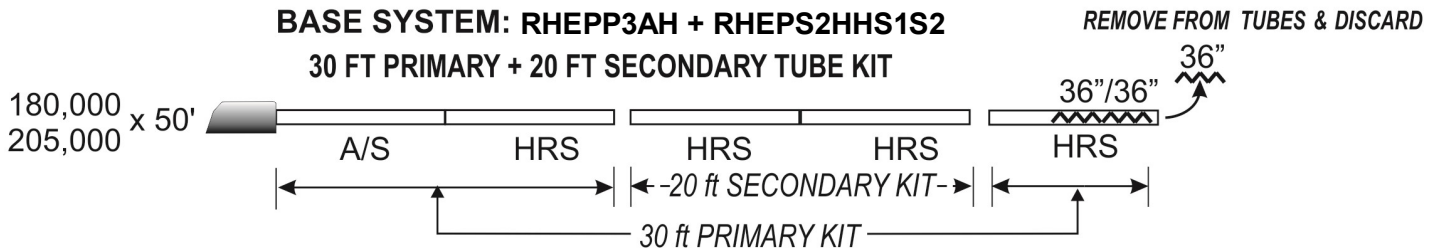

BASE SYSTEM: RHEPP4SS + RHEPS2HHS1S2

40 FT PRIMARY + 20 FT SECONDARY TUBE KIT

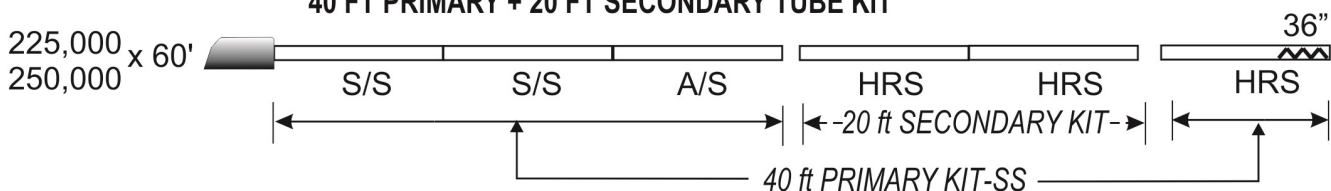

4. COMBUSTION AIR DUCTING

Do not install filters on the combustion air intake. Ensure adequate clearance around the air intake to allow sufficient combustion air supply to the burner.

Air duct is typically 4" diameter, but inputs 205,000 and greater require a minimum 5" diameter duct (reduce to 4" at burner connection). Any 4" duct can be increased to 5" diameter to allow up to an additional 20 feet of duct length.

Combustion air duct must be constructed of noncombustible material. **Do not use a 'soft wall' flexible hose** for air duct, the corrugated sides of this tubing will contract and restrict air flow. A good quality industry approved hard-wall flex is allowed.

When a tube heater is operated in a negative air condition or air-borne dust or contaminants are present as in woodworking, and welding shops, air for combustion must be ducted from outside the negative or contaminated area to the 4 inch (10 cm) diameter intake flange supplied on the blower. Maximum system, vent and duct length is listed above.

- Do not exceed lengths listed above for total system and individual vent or air duct
- Total combined system length is reduced by five feet for every 90° elbow installed in the vent or duct *and* in the tube system (see above for allowable total lengths)
- Exceeding the allowable lengths may create condensation or soot conditions and will void product certification and warranty

The air intake will not be located less than:

- Three feet above grade
- Twelve inches from flue vent terminal of any heater with input up to 100,000 Btu/hr
- Three feet from flue vent terminal of any heater over 100,000 Btu/hr

An optional horizontal fresh air intake hood (908000021) is available to bring combustion air to the heater from an outside wall. If dropping air duct down from the roof, use an approved rain cap for the duct terminal. Ensure adequate clearance around the air intake to allow sufficient combustion air supply to the heater. When drawing fresh air from outside, it is recommended that any single wall pipe containing cold air be insulated to reduce condensation on the pipe surface.

NOTE: When outside-air duct drops down from the roof:

- Drop air duct to a Tee / drip leg to the side of the burner
- This will potentially reduce condensate and other moisture accumulation at the blower

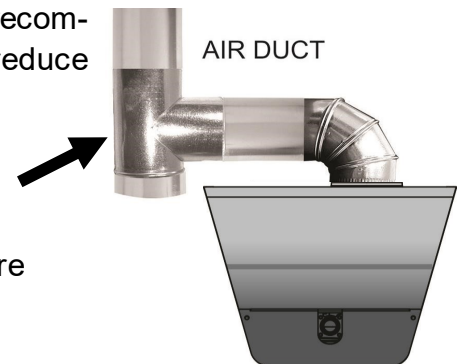

CAUTION:



In locations where chlorinated Hydrocarbons are in use, such as Trichloroethylene or Chloroethylene Nu it is essential that combustion air be brought in from a non-contaminated area. Burning the fumes from these gases will create Hydrochloric acid fumes, which are detrimental to humans, equipment and buildings. Typical sources of other contaminants are paint removers, paints, refrigerants, solvents, adhesives, degreasers, lubricants, pesticides, etc.



The heater manufacturer cannot anticipate all types nor chemical composition of potential contaminants at project sites. Prior to installation, confer with project site safety, health and engineering staff and/or local authorities having jurisdiction such as the Fire Marshall and Department of Labor for possible contaminants and any conflict with the installation of hot surface heating equipment.

5. FLUE VENTING - RADIANT TUBE HEATER



IMPORTANT

Effective immediately for this tube heater series: Changes to the ANSI/CSA standard that governs Radiant Tube Heaters specify the following appliance CATEGORIES and VENTING:

- **Vertical Vent Through Roof (Category I):** When vented vertically, this tube heater series operates with a negative static vent pressure and a vent temperature that does not result in excessive condensate in the vent and is defined as a Category I appliance. Refer to details below.
- **Horizontal Vent Through Wall (Category III):** For horizontal vent, this tube heater series operates with a positive static vent pressure and a vent temperature that does not result in excessive condensate in the vent and is considered a Category III appliance. Refer to details below.



WARNING

Inadequate venting of a heater may result in asphyxiation, carbon monoxide poisoning, injury or death. This heater may use a vent connection or indirect venting system to remove products of combustion from the space. Seal all vent connections with high temperature sealant. Venting must be in accordance with all local, state, provincial, and national codes (ANSI Z223.1/NFPA 54 in USA) and as indicated below in this manual.

THIS TUBE HEATER IS CERTIFIED FOR VENTING DIRECTLY TO THE OUTSIDE OR UNVENTED (INDIRECT VENTING) APPLICATIONS.



UNVENTED (INDIRECT MECHANICAL VENTING SYSTEM)

USA: Natural or mechanical means shall be provided to supply and exhaust at least 4ft³/min/1000Btuh (0.38m³/min/kW) input of installed heaters. Some local codes may require an electrical interlock to a dedicated exhaust fan. Exhaust must be located as high as practicable in the structure above the level of the heater(s). Consult your local code and ANSI Z223.1 latest edition for all venting requirements and practices.

VENTED TO THE OUTSIDE - GENERAL REQUIREMENTS

It is the responsibility of the installer to adhere to these instructions and all current local codes and/or ANSI Z223.1 (NFPA 54) latest editions for all venting requirements, and practices. All vent pipe will be certified to meet Category I (vertical vent) or Category III (horizontal vent) appliance requirements, depending on the vent configuration of a particular installation.

It is a normal condition that during heat-up and cool-down a tube heater will expand and contract. Allowances for heater expansion must be made in the venting and combustion air ducting. Improper installation can result in property damage, injury or death.

- When vented: The system must not be operated in a negative air condition unless combustion air is ducted from outside to the burner. If negative pressure is experienced or anticipated, the open port (barb) on each of the blocked flue and proving air switches must be Tee'd together and connected directly to outside air using a field supplied 1/4" plastic hose from the tee between the switches to outside of building.
- All approved vent pipe, connectors, and adapters are supplied locally by others according to appliance Category, and specifications below
- Do not mix vent components from different manufacturers in the vent system
- All venting must meet requirements of Local Codes or, in the absence of local codes, with the *National Fuel Gas Code*, ANSI Z223.1/NFPA 54.
- A vent connector shall comply with local codes and be firmly attached to the flue collar by 3 x

1/2" sheet metal screws

- Install a minimum 12" [305 mm] straight vent connector before any Tee or 90° Elbow
- The connection of vent components must be secured as specified in the installation instructions by the vent manufacturer.
- For vertical vent, any horizontal vent section will slope upwards away from the heater not less than 1/4 inch rise per foot of run.
- For horizontal vent, slope downward away from heater a maximum of 1/4 inch down per foot of run
- When the vent pipe passes through a cold or unheated area where the ambient temperature is likely to produce condensation of the flue gases, the vent pipe will be insulated with a suitable material as certified and specified by the insulation manufacturer to withstand temperature up to 460°F (238°C).
- The vent system must **always** be adequately supported to prevent sagging.
- The vent configuration will allow for expansion and contraction in length of the tube heater
- As an Option for vertical vent, two heaters may be vented through an approved common 4" x 4" x 6" Vent Tee (10 x 10 x 15 cm), supplied by the manufacturer, or by using approved components as indicated in local codes. Vent pipe from each heater is not required to be equidistant to the vent Tee, but must comply with local code requirements. A common thermostat or "ON/OFF" switch must control the two commonly vented heaters. Common vent is not allowed for Category III horizontal vent application.

COMBINED SYSTEM LENGTH: Tube Heater + Vent + Combustion Air Duct:

- **Refer to Table 4 next page, COMBINED SYSTEM LENGTH: TUBE + AIR DUCT + VENT.** Lengths in the table apply to either Vertical or Horizontal vent.
- **COMBINED SYSTEM LENGTH includes:** Tube Heater length + combustion air duct + vent + elbows. Each 90° elbow in the system has an equivalent length of 5 ft.
- A maximum of 2 elbows is allowed in any portion (duct, tube heater, vent) with the exception of up to three 90° elbows in a vertical vent run through the roof, for a total of maximum 6 (vertical vent: 7) 90° elbows in the combined system
- Combustion air duct is not to exceed lengths in table below and may be 4" or 5" diameter for inputs less than 200,000 Btuh, but must be 5" diameter for inputs 200,000 Btuh and greater
 - 5" diameter duct requires a reducer to 4" diameter at the connection to blower inlet
- Exceeding the allowable lengths in the table below can create combustion and/or condensation issues and will void Certification and the heater warranty.
- Do not exceed the **Maximum Combined System Length** regardless of the allowed maximum length of individual vent or combustion air duct

TABLE 4 COMBINED SYSTEM LENGTH: TUBE + AIR DUCT + VENT

| TWO-STAGE Input (Btuh) | Do Not Exceed Maximum Combined System Length | | Max. Air Duct Length (by Duct Diameter) | | Max. Vent Length Individual: 4"Ø OR Combined: 6"Ø | Example |
|------------------------|--|------------------|---|-------|--|--|
| | With 4" Air Duct | With 5" Air Duct | 4" Ø | 5" Ø | | |
| 50,000 & 65,000 | 70 ft | 80 ft | 20 ft | 30 ft | 30 ft | 155,000 Btuh Heater: Tube Heater Length 50 ft 1 x 90° elbow (vent) 5 ft Straight vent 15 ft 1 x 90° elbow (duct) 5 ft Air Duct: 4" Ø <u>15 ft</u> Combined Length 90 ft Max. Allowed 90 ft Additional 10' for 5" Ø Air Duct |
| 80,000 & 115,000 | 80 ft | 90 ft | 20 ft | 30 ft | 30 ft | |
| 130,000 & 155,000 | 90 ft | 100 ft | 20 ft | 30 ft | 30 ft | |
| 180,000 | 100 ft | 110 ft | 20 ft | 30 ft | 30 ft | |
| 205,000 | Use 5"Ø | 110 ft | Use 5"Ø | 30 ft | 30 ft | |
| 225,000 to 250,000 | Use 5"Ø | 120 ft | Use 5"Ø | 30 ft | 30 ft | |

HEATER EXPANSION AND VENT CONFIGURATION

A radiant tube heater will expand and contract as it heats and cools. Configuration of the vent must allow for heater expansion.

VERTICAL VENT: Orientation of the vent at 90° to heater will allow for heater expansion and contraction.

HORIZONTAL VENT: (See FIG. 6)

- Wall Thimble or flashing at wall that allows movement of the vent through the opening. Do not seal the vent to the thimble or flashing with caulking

OR

- Offset vent with two x 90° elbows. Install minimum 12 inch [305 mm] length of straight vent between elbows. Vent can be sealed with caulking at non-combustible wall.
- Other means of slip fit installation of the vent are acceptable providing there is adequate allowance for free expansion and contraction of the system, and free flow of vent gases.

FIGURE 6: ALLOW FOR HEATER EXPANSION - HORIZONTAL VENT - TOP VIEW

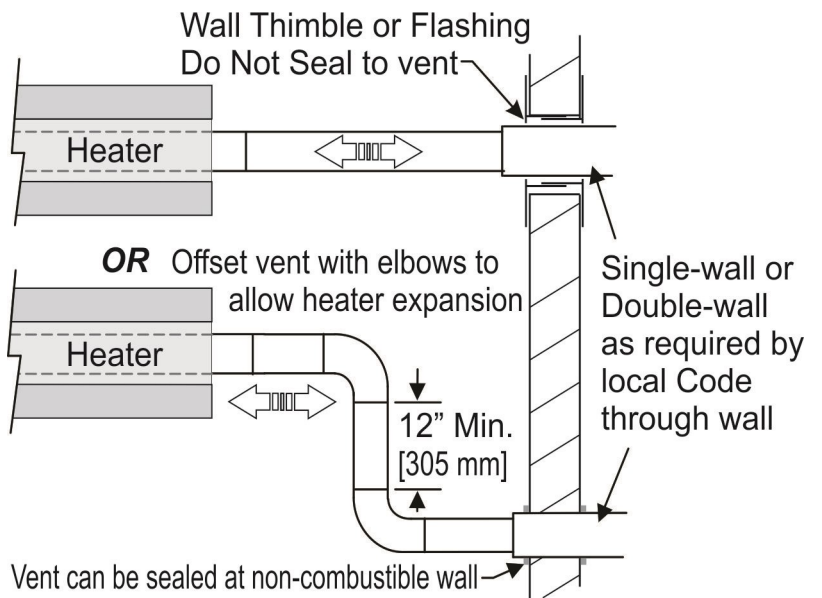

COMMON VENTING

For vertical vent only, two heaters can be commonly vented using 4"x 6"x 4" Vent Tee 902000008. Both heaters must be operated using one common thermostat. Common vent is 6 inch [150 mm] diameter.

Category III (horizontal vent) heaters cannot be common vented.

VERTICAL VENT THROUGH THE ROOF (CATEGORY I):

It is the sole responsibility of the installer to adhere to all current local codes and/or ANSI Z223.1 latest editions for all venting requirements, and practices. Also adhere to instructions below, and the instructions of the vent manufacturer. Use vent materials certified for Category I.

All models of this series heater are certified Category I for vertical venting. See FIG. 5.

- The vent must extend at least 5 feet [1524 mm] above the flue collar of the highest connected heater
- USA: Horizontal run of single wall vent or vent connector (“H” in FIG 5) must not exceed 75% of the vertical height of the vent. If it does, then the vent system must be for Category III.
- Inputs up to 170,000 Btuh vertical vent can be 4” diameter Type B-Vent; greater than 170,000 Btuh must use 5” diameter Type B-Vent
- A vent connector must be secured to the flue collar using quantity 3 x #8 x 1/2” sheet metal screws
- A horizontal vent connector shall be installed and supported without any dips or sags and shall slope upward toward the vent or chimney at least 1/4 in./ft (20 mm/m).
- Use a certified termination cap as supplied by the manufacturer of the vent
- When vent and combustion air are taken through the roof, the exhaust vent should always terminate higher than the combustion air intake, to prevent recycling the products of combustion back into the heater
- The vent must extend at least 2 feet [610 mm] above the highest point where it passes through a roof. The vent must also extend at least two feet higher than any portion of a building within a horizontal distance of 10 feet [3 m].
- Keep vent connector runs as short as possible with a minimum number of elbows. Refer to the current edition of AN-SI Z223.1 (NFPA 54) installation codes for maximum length of horizontal vent and vent connector.
- Total length of the vent connector and vent pipe cannot exceed the values in Table 4 above.
- A single-wall vent connector shall not be insulated.
- For single-wall vent clearance to combustibles is 6" [152mm] except where a listed clearance thimble is used. Clearance to combustible material for Type B-Vent or factory-built vent per the vent manufacturer's instructions.

FIGURE 7: VERTICAL VENT

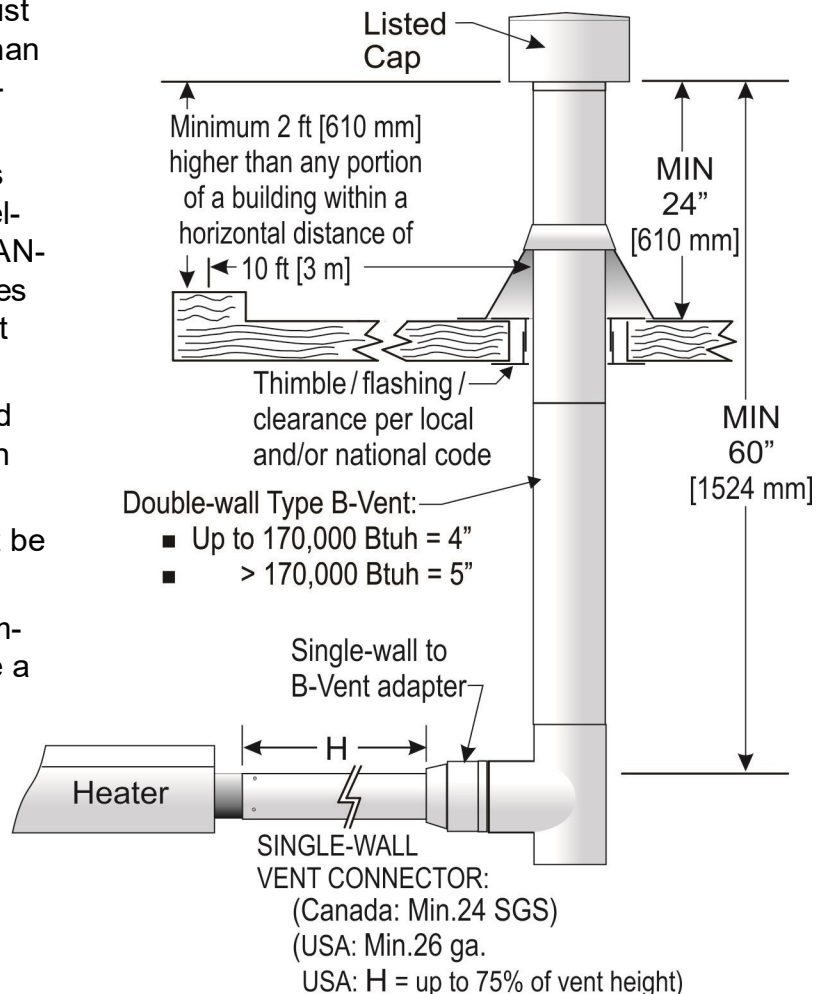

HORIZONTAL VENT THROUGH THE SIDEWALL (CATEGORY III):

- When installed with a horizontal vent through a sidewall, this heater is a Category III appliance, and venting materials must be approved for Category III applications.
- All vent must be installed in accordance with local codes or, in the absence of local codes, with the *National Fuel Gas Code*, ANSI Z223.1/NFPA 54.
- All vent must installed in accordance with these instructions, and the instructions of the vent manufacturer.
- Do not mix vent components from different manufacturers in the vent system
- A single wall vent system may use a single continuous section of double wall vent pipe to pass through an exterior wall.
- Any horizontal portion of the flue vent system must slope downwards away from the heater a minimum of 1/4" per foot run [63 mm/ 300 mm] toward the vent terminal.
- All vent pipe from a single heater must be 4" [102 mm] diameter; common vent pipe for two heaters must increase to 6" [152 mm] at the point of connection of individual 4" vents
- Use approved 4" [102 mm] (902000002) or 6" [152 mm] (902000007) horizontal wall vent terminal or an approved high-wind termination cap
- Installation of the vent must prevent blockage by snow and protect building materials from degradation by flue gases.
- Install termination cap a minimum of 18 inches (45 cm) from the outside wall to the inside edge of terminal opening to alleviate back pressure caused by turbulent wind conditions (See Fig. 8). This also ensures flue gases are directed away from the structure to protect building materials from degradation by the exhausted flue gases.
- At most two 90° elbows can be installed in a horizontal vent
- A horizontal flue vent will not terminate less than 1 ft [30 cm] above grade level, unless its location is adjacent to public walkways, then it must not terminate less than 7 ft [2.1m] above the walkway.
- Clearance below a combustible overhang or soffit:
 - As indicated in FIGURE 8 for approved terminations: 4" [100 mm] 902000002 or 6" [150 mm] 902000000.
 - For other approved terminations: Will terminate 3 ft [915 mm] or more below a combustible soffit or overhang.
- A horizontal vent termination must be a minimum of 6 feet [1830 mm] from an inside corner formed by two exterior walls.
- A venting system shall be securely supported by noncombustible hangers suitable for the weight of the materials.
- A slip joint in the horizontal section of a venting system shall be secured with quantity 3 x #8 x 1/2" sheet metal screws to prevent sagging.
- Seal single-wall vent seams and joints with Dow Corning 736 Heat Resistant Sealant 600°F [315°C] or equivalent, or follow the instructions of the vent manufacturer for sealing vent pipe connections

USA specific requirements for horizontal vent are on the next page

USA specific horizontal vent requirements:

- The vent terminal of an appliance with an input up to 50,000 Btu/hr (14.7kW) shall be installed with a 9 inch [230mm] vent termination clearance from any air opening into a building, and an appliance with an input over 50,000 Btu/hr (14.7kW) shall have at least a 12 inch [305 mm] vent termination clearance. The bottom of the vent terminal and the air intake shall be located at least 12 inches [305 mm] above grade.
- A horizontal vent will not terminate:
 - Less than 3 ft [915 mm] above a mechanical air inlet located within 10 ft [3 m]
 - Less than 4 ft [1219 mm] below, 4 ft [1219 mm] horizontally from, and 1 ft [102 mm] above any window or door that opens, or gravity air inlet to a building
 - Less than 4 ft [1219 mm] horizontal clearance from gas and electric meters, regulators and relief equipment

FIGURE 8: HORIZONTAL VENT THROUGH WALL

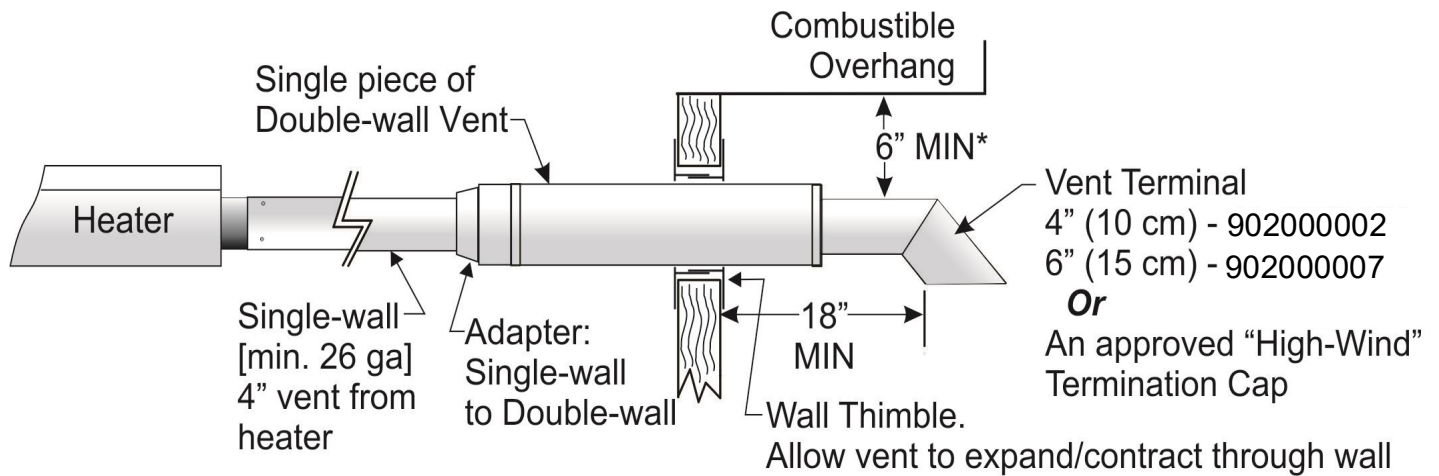

* 6" Clearance Above applies to optional Vent Terminal:
902000002 - 4" (10 cm); or 902000007 - 6" (15 cm)
Use of alternate High-Wind terminal may require higher clearance. Refer to Vent Cap manufacturer's instructions.

6. GAS SUPPLY: MINIMUM / MAXIMUM & MANIFOLD PRESSURES

- Refer to General Manual for requirements on gas supply and flexible gas connection to the heater.

TABLE 5 Manifold Pressure - Two Stage Models

| INPUT | FUEL TYPE | LINE PRESSURE | | MANIFOLD PRESSURE (tap at gas valve outlet) INCHES WATER COLUMN |
|-----------|-------------|--------------------------------|--------------------------------|--|
| | | INCHES WATER COLUMN MINIMUM | INCHES WATER COLUMN MAXIMUM | |
| TWO-STAGE | Natural Gas | 5.0 | 14.0 | 3.5 / 2.0 (4.2 / 2.0 FOR 225&250 MBH) |
| | Propane | 11.0 | 14.0 | 10.0 / 5.0 |

7. ELECTRICAL AND THERMOSTAT WIRING (WIRING DIAGRAMS NEXT PAGES)



NOTICE

The heater must be electrically grounded in accordance with the National Electrical Code. ANSI / NFPA 70.

Appliance and control wiring must be in accordance with all applicable local codes. The total load of all heaters must be considered in determining the required contact rating of the controlling thermostat or switch. Each tube heater requires 120V, 60 HZ electrical power sized for 145VA. Maximum power flow for internal 24V burner components is 21VA.

The Fenwal ignition control includes a 24V/120V relay switch that provides a 45 second pre-purge and 45 second post-purge of the system. To maintain function of the post-purge feature, any **Thermostat / control must be installed in the thermostat circuit from the terminal block (TR - TW)**. A line voltage Thermostat or an "ON/OFF" control switch installed in the 120VAC power supply will disable the post-purge feature.

A maximum night set-back of 9°F (5°C) is recommended for optimum economy and comfort. To maintain satisfactory comfort levels do not turn off the heating system over night/weekends.

8A. HE+ SERIES WIRING DIAGRAM: 24V OR 120 VOLT THERMOSTAT OPERATION
SINGLE HEATER PER THERMOSTAT *(Multiple Heaters per Thermostat—next page)*

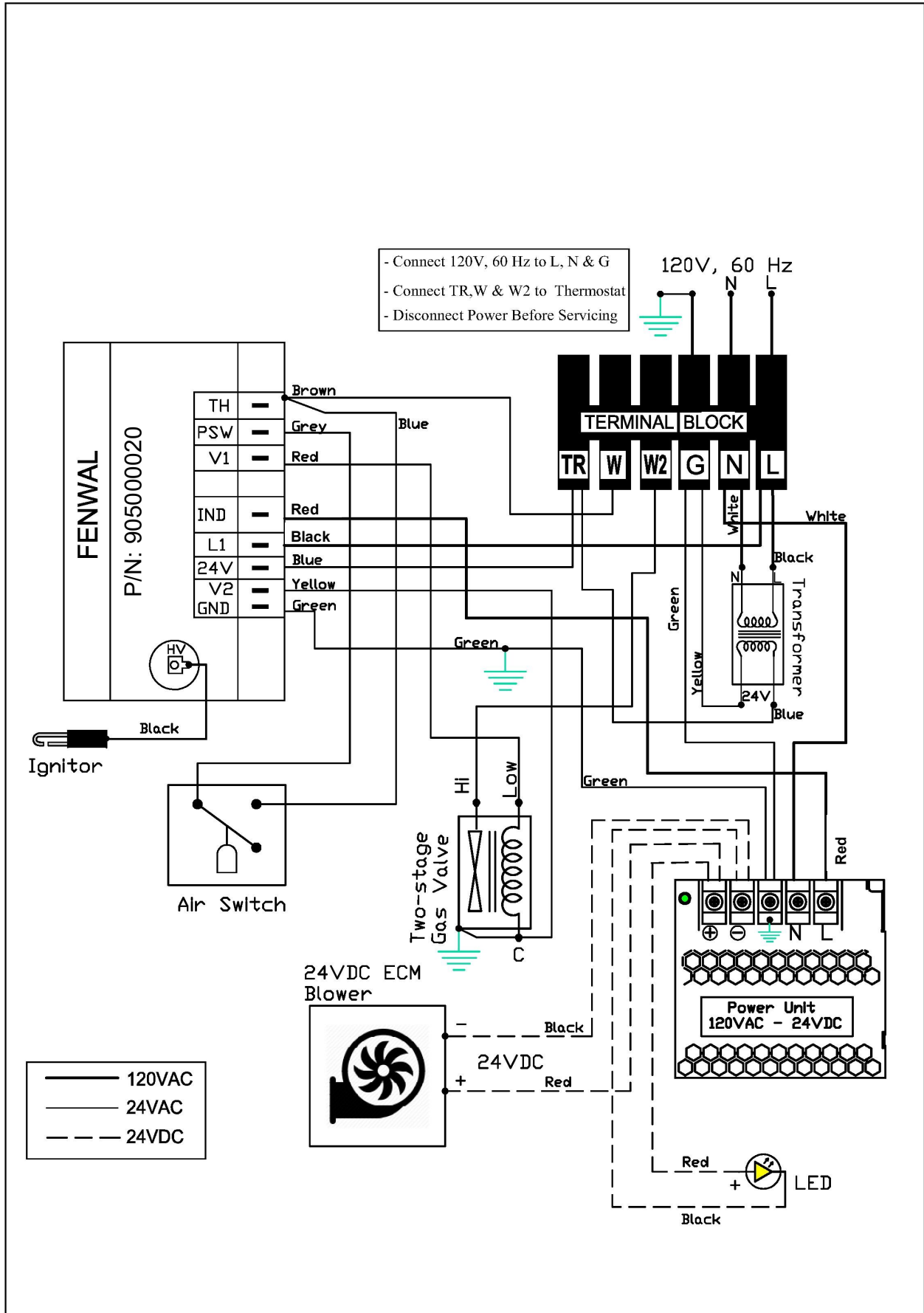

8B. MULTIPLE TUBE HEATERS per COMMON THERMOSTAT

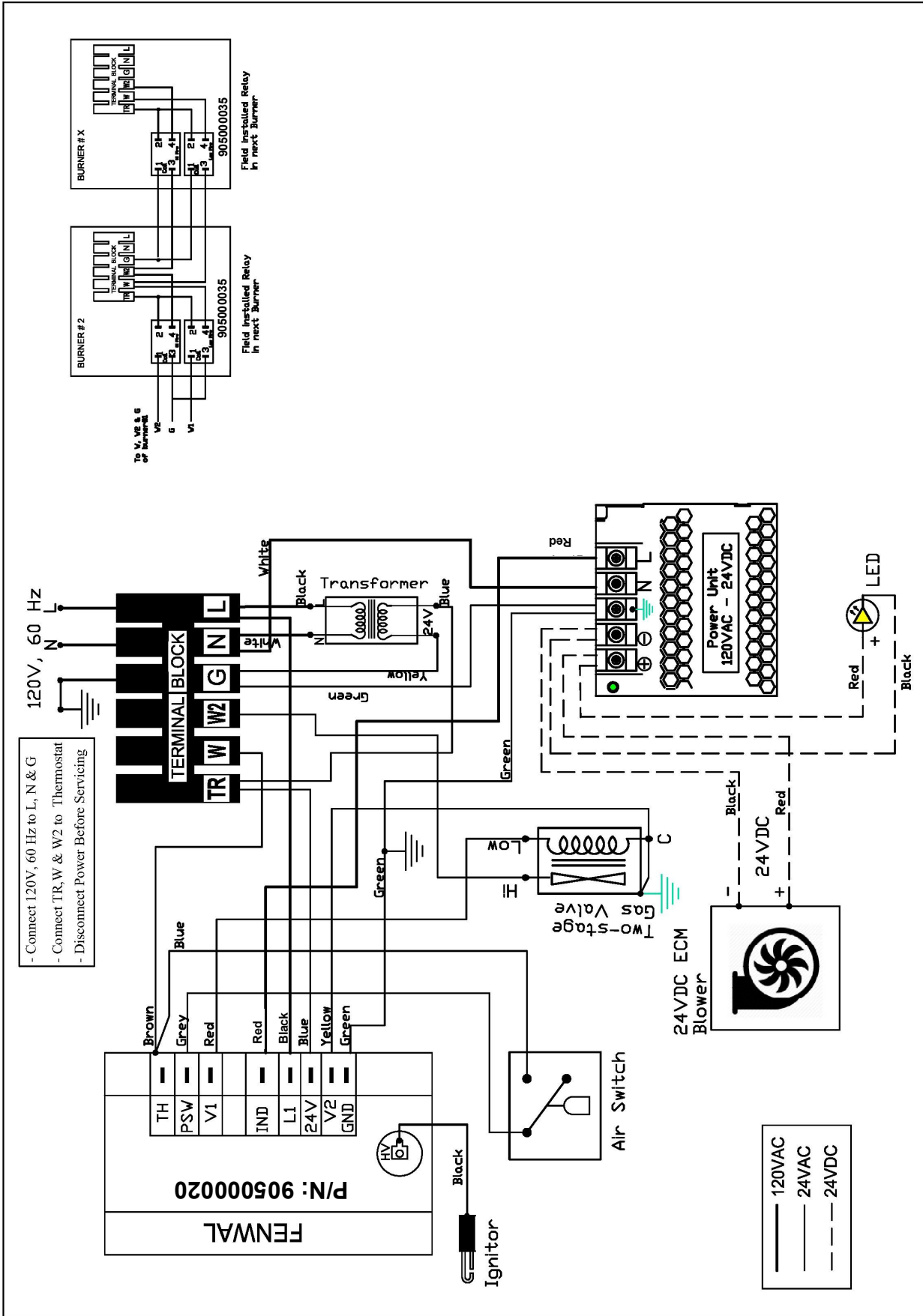

9. FENWAL DSI: SEQUENCE OF OPERATION / FLAME RECOVERY / SAFETY LOCKOUT

Power Up / Stand By

Upon applying 24 volts power to 24VAC, the control will reset, perform a self check routine, initiate full time flame sensing, and enter the thermostat scan state.

Heat Mode

When a call for heat is received from the thermostat supplying 24 volts to TH, the control checks the pressure switch for normally open contacts. The combustion blower is then energized and once the pressure switch contacts close, a 30 second purge delay begins. Following the purge period the gas valve is energized and spark commences for the 15 second trial for ignition.

When flame is detected during the trial for ignition, spark is shutoff immediately and the gas valve combustion blower remains energized. The thermostat, pressure switch, and main burner flame are constantly monitored to assure the system continues to operate properly. When the thermostat is satisfied and the demand for heat ends, the main valve is de-energized immediately, the control senses the loss of flame signal and initiates a 30 second post-purge period before de-energizing the combustion blower.

Failure to Ignite - Lockout (THREE TRIAL MODEL)

This three-try control will attempt two additional ignition trials with a 30 second inter-purge between trials, before going into 'soft' lockout. The valve relay will be de-energized immediately, and the combustion blower will be turned off following the 30 second post purge period.

If the thermostat continues to call for heat after one hour the control will automatically reset and attempt to ignite the burner again (three trials).

At any time less than the 1 hour auto-reset, recovery from lockout requires a manual reset by either resetting the thermostat or removing 24 volts for a period of 5 seconds.

Flame Failure - Re-cycle

If the established flame signal is lost while the burner is operating, the control will go to recycle mode. The HV spark will be energized for a trial ignition period in an attempt to relight the burner. If the burner does not light the control will de-energize the gas valve. Two more attempts will be made to relight the burner. If the burner does not relight the control will go into 'soft' lockout as noted above in "Failure to Light". If flame is re-established, normal operation resumes.

Combustion Airflow Problems -Lockout

Combustion air flow is continually monitored during an ignition sequence by the air flow switch (PSW). If during the initial call for heat the pressure contacts are in the closed position for 30 seconds without an output to the Combustion Blower, an air flow fault will be declared and the control will remain in this mode with the combustion blower off.

If the air flow switch remains open for more than 30 seconds after the combustion blower output (L1 & IND) is energized, an air flow fault will be declared and the control will stay in this mode with the combustion blower on, waiting for the air flow switch to close.

When proper air flow is detected from the air flow switch input (PSW) the control begins the pre-purge period followed with a 15 second ignition sequence.

If the air flow signal is lost while the burner is firing, the control will immediately de-energize the gas valve and the combustion blower will remain on. If the call for heat remains, the control will wait for proper air flow to return. If proper air flow is not detected after 30 seconds an air flow fault signal will be declared. If proper air flow is detected at any time, a normal sequence will begin with the pre-purge period.

Flame Fault

If at any time the main valve fails to close completely and maintains a flame, the full time flame sense circuit will detect it and energize the combustion blower. Should the main valve later close completely removing the flame signal, the combustion blower will power off following the optional post purge period.

MOUNTING AND WIRING

The Fenwal DSI Control 24 VAC Tube Heater (905000020) is not position sensitive and can be mounted vertically or horizontally. The case may be mounted on any surface with #6 sheet metal screws. All wiring must be done in accordance with local and national electrical code. Refer to wire diagram page 35 when connecting 905000020 to other components in the burner.



WARNING

The Fenwal DSI Control 24 VAC Tube Heater (905000020) uses voltages of shock hazard potential. Wiring and initial operation must be done by a qualified service technician. The control must be secured in an area that will experience a minimum of vibration and remain below the operating temperature of 160°F. All connections should be made with UL approved 105°C rated 18 gauge, stranded, .054 thick insulated wire. Refer to wire diagram page 35 when connecting the Series 35-61 to other components in the burner.

| TERMI-NAL | SPADE | DESIGNATION |
|-----------|-------|----------------------------|
| TH | 1/4" | Thermostat Input |
| PSW | 1/4" | Pressure Switch Input |
| V1 | 1/8" | Valve Power (MV) |
| IND | 1/4" | Inducer Blower Output |
| NC | - | Alarm (Not used) |
| L1 | 1/4" | 120/240 VAC Input (Hot) |
| 24 VAC | 1/4" | 24 VAC Supply to Processor |
| V2 | 1/8" | Valve (MV) |
| GND | 1/8" | Valve & System Ground |
| Spark | 1/4" | Spark & Local Flame Sense |

CAUTION:

Label all wires prior to disconnection when servicing controls. Wiring errors can cause improper and dangerous operation. A functional checkout of a replacement control is recommended.

PROPER ELECTRODE LOCATION

Proper location of the electrode assembly is important for optimum system performance. The electrode assembly should be located so that the spark gap is inside the flame envelope about 1 inch (2.5 cm) from the base of the flame at the burner cup.

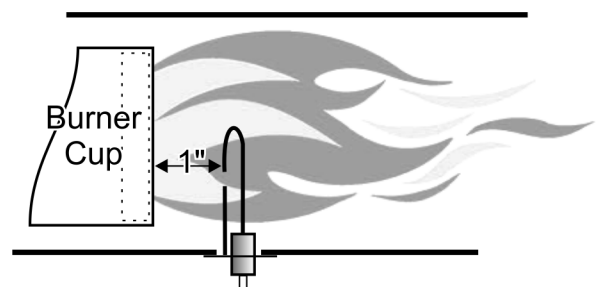

Electrodes should have a gap spacing of 3/16" (0.188" ± 0.031" or 4.76 mm ± 0.81 mm). If this spacing is not correct, the assembly must be adjusted or replaced. DO NOT adjust the curved igniter/sensor prong. Adjust/bend only the ground prong (also see next page).

SPARK IGNITER SET UP

Use the following diagram to check the Igniter gap. If the gap is incorrect all adjustments should be made to the **GROUND PRONG/PIN ONLY! DO NOT BEND THE IGNITER PRONG!!!!**

USE THE BLACK BARS BELOW AS A GUIDE FOR ADJUSTMENT. USE THE BARS THAT COINCIDE WITH THE FORMAT & SIZE OF THIS PUBLICATION .

IF this manual is in

8.5" x 11" "booklet" format
(pages folded in half)

3/16"

1/4"



then use these bars

OR

IF this manual is printed 8.5" x 11" "**full page**" format

3/16"

1/4"



use these bars

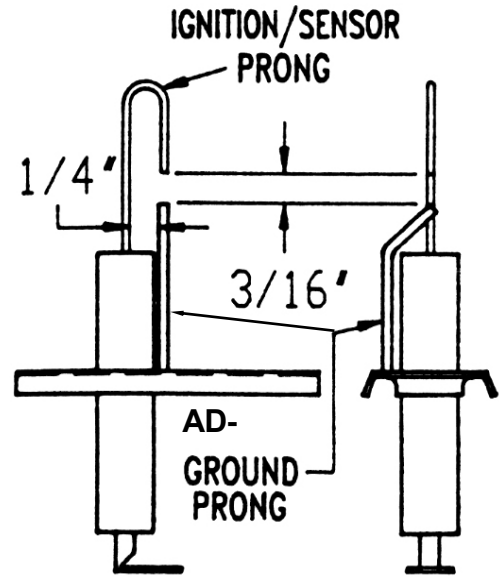

SERVICE CHECKS

Flame current passes through the flame from the sensor to ground. The minimum flame current necessary to keep the system from lock-out is 0.7 microamps. To measure flame current, connect an analog DC microammeter to the FC- FC+ terminals per figure at right.

Meter should read 0.7 μ A or higher. If the meter reads below "0" on scale, meter leads are reversed. Disconnect power and reconnect meter leads for proper polarity.

Multipurpose Meter

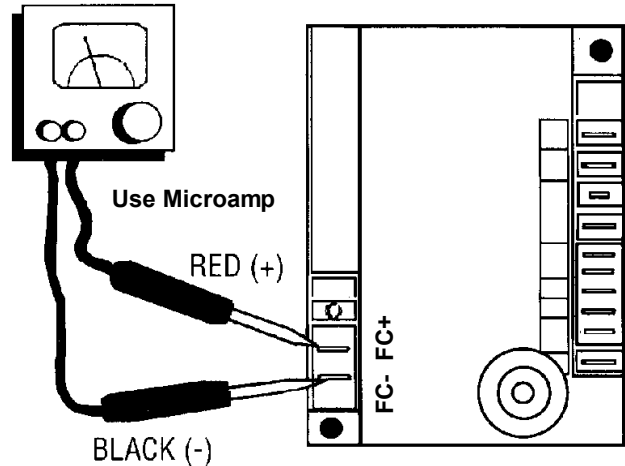

10. TROUBLESHOOTING GUIDE - FENWAL DSI

(also see Heater Troubleshooting next page)

| SYMPTOM | RECOMMENDED ACTION(S) |
|--|--|
| 1. Dead | <ul style="list-style-type: none"> A. Miswired - check electrical supply (120Vac \pm 5%) B. Transformer bad (24Vac \pm 10%) C. Fuse/Circuit breaker bad D. Bad control (check LED for steady on) E. 24VDC Power Unit is bad |
| 2. Thermostat on - no blower output | <ul style="list-style-type: none"> A. Miswired B. Bad thermostat no voltage @ terminal W C. Bad control (check LED for steady on) D. 24VDC Power Unit is bad |
| 3. Pressure switch input okay, but no Trial-for- ignition after purge delay | <ul style="list-style-type: none"> A. Miswired (check PSW terminal voltage: 24Vac \pm 10%) B. Flame sense problem (existing flame: check LED - 2 flashes) C. Bad control (check line voltage between L1 & IND) |
| 4. Valve on, no spark | <ul style="list-style-type: none"> A. Shorted electrode B. Open HV cable C. Bad control |
| 5. Spark on, no valve | <ul style="list-style-type: none"> A. Valve coil open B. Open valve wire C. Bad control (check 24Vac voltage between V1 & V2) |
| 6. Flame ok during TFI, no flame sense (after TFI) | <ul style="list-style-type: none"> A. Bad electrode B. Bad HV igniter wire C. Poor ground at burner D. Poor flame (check flame current) |

11. TROUBLESHOOTING GUIDE - HEATER OPERATION



WARNING

Improper adjustment, alteration, service or maintenance can cause property damage, injury or death. This heater must be installed and serviced only by a trained gas service technician

SEQUENCE OF EVENTS (also see *DSI Troubleshooting previous page*)

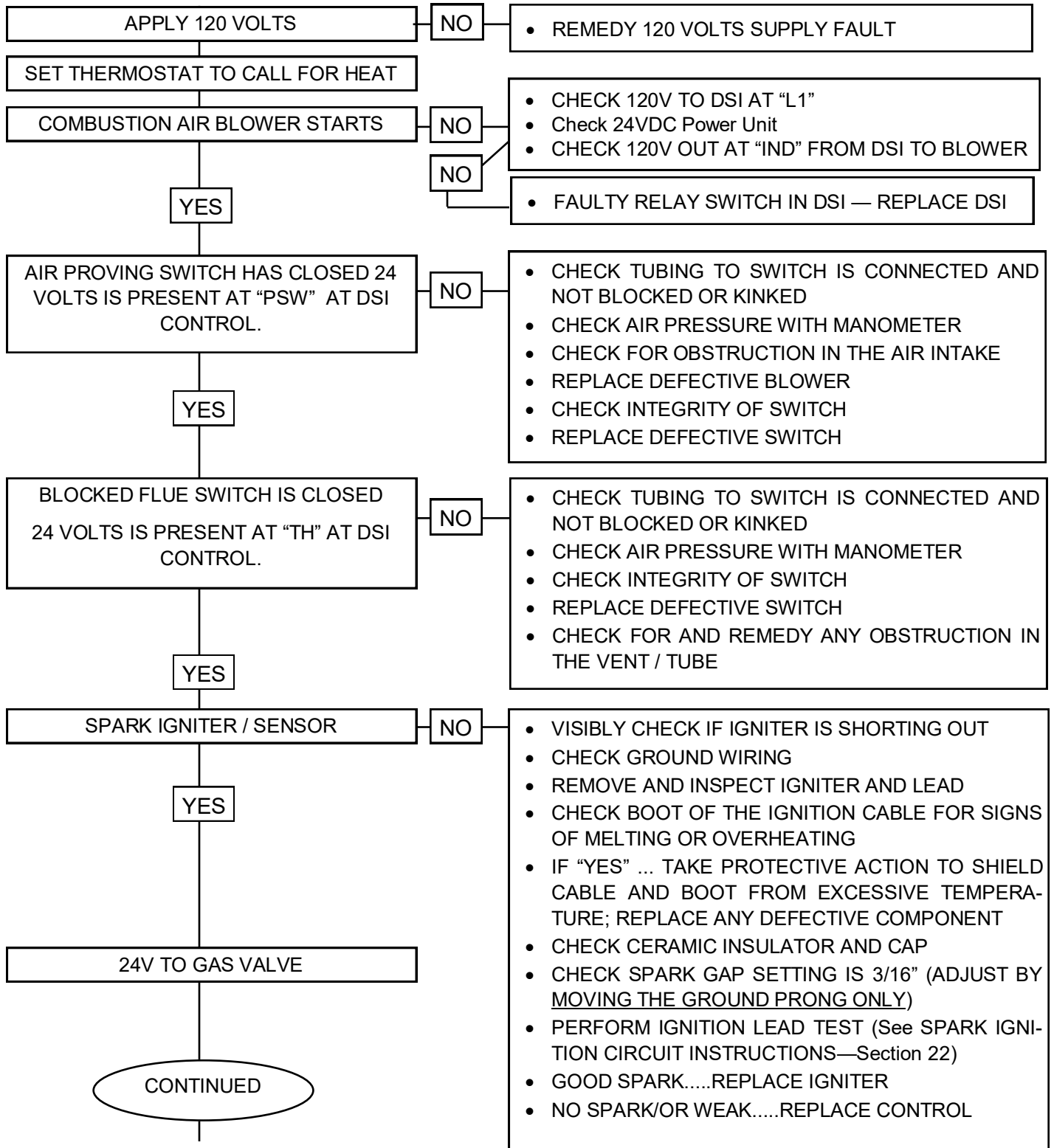

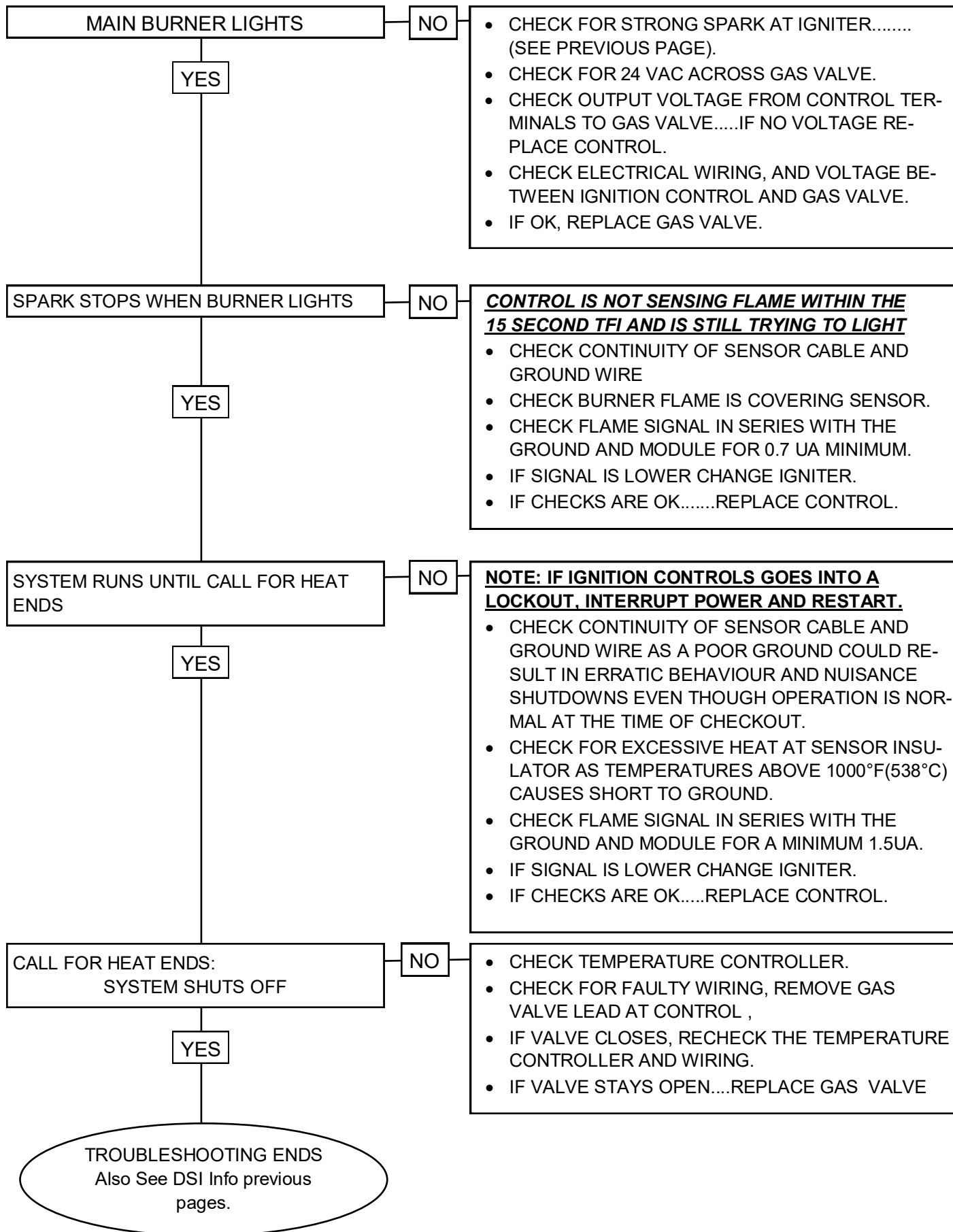

12. START-UP / COMMISSIONING SHEET



THIS EQUIPMENT HAS BEEN FACTORY FIRED AND TESTED PRIOR TO SHIPMENT. HOWEVER, THIS APPLIANCE IS NOT “PLUG & PLAY”. IT REQUIRES COMMISSIONING AND FIELD ADJUSTMENT / SPECIFICATIONS CONFIRMATION TO ENSURE SAFE AND EFFICIENT OPERATION.

COMMISSIONING REPORT AS PER I&O MANUAL AND LOCAL CODES

CONTRACTOR NAME:DATE.....

ADDRESS:.....
.....

CITY:.....

PHONE:.....

CELL:

JOB SITE.....CITY.....

HEATER MODEL NUMBER:.....
Located on burner rating plate

HEATER SERIAL NUMBER:

TO ENSURE THAT SITE CONDITIONS ARE COMPATIBLE WITH THE HEATER’S PERFORMANCE AND TO ALLEVIATE NUISANCE CALL-BACKS, THE FOLLOWING START-UP NEEDS TO BE COMPLETED BY THE QUALIFIED GAS INSTALLER.



WARNING

START UP ‘SMOKE’

During start up, material coatings used in the production process of tubes and reflectors will “burn off” and create smoke during the first hour of operation. This is temporary and normal.

Please ensure that there is sufficient ventilation to adequately clear the smoke from the space.

Notify site and safety personnel to ensure that alarm systems are not unduly activated.

QUALIFIED INSTALLER TO COMPLETE THIS

TYPE OF GAS: NG LP

DOES BUILDING HAVE A NEGATIVE CONDITION: YES NO

IF THIS IS A HIGH ALTITUDE AREA WHAT IS THE ALTITUDE ABOVE SEA LEVEL Ft

DOES APPLICATION REQUIRE FRESH AIR TO BURNER YES NO

IS HEATER EXPOSED TO CHEMICAL OR CORROSIVE ATMOSPHERE: YES NO

ARE ACTUAL MINIMUM CLEARANCES AS PER TABLE 3 YES NO

CAN HEATER BE AFFECTED BY OVERHEAD CRANES / VIBRATION YES NO

ARE GAS SUPPLY LINES ADEQUATELY SIZED FOR SYSTEM YES NO

GAS LINES AND BRANCHES HAVE BEEN PURGED OF AIR: YES NO

THIS HEATER FIRED WITHOUT ANY MALFUNCTION: YES NO

INLET GAS SUPPLY PRESSURE WITH HEATER OPERATING : WC"

GAS VALVE OUTLET (Manifold) PRESSURE WITH HEATER OPERATING: WC"

WHAT IS THE LINE VOLTAGE READING AT THE HEATER VOLTS

WHAT IS THE VOLTAGE READING AT THE IGNITION MODULE VOLTS

WHAT IS THE FLAME SIGNAL STRENGTH IN uA FROM SENSOR: uA (microamps)

IS HEATER CONTROLLED BY A THERMOSTAT YES NO

IS THE THERMOSTAT STRATEGICALY LOCATED YES NO

WHAT IS TOTAL LENGTH OF INSTALLED THERMOSTAT WIRE FEET

WHAT IS THE GAUGE OF THE THERMOSTAT WIRE GAUGE

WHAT IS THE HEATER TUBE LENGTH (10ft per Tube section) FEET

WHAT IS THE TOTAL LENGTH OF THE VENT (add 10ft for each bend) FEET

WHAT LENGTH IS COMBUSTION AIR INTAKE (add 10ft for each bend) FEET

IF REQUIRED....WHAT IS THE LENGTH OF THE TURBULATOR(S) FEET

IF INSTALLED....IS TURBULATOR AT FLUE END OF SYSTEM YES NO

"MAXIMUM STACKING HEIGHT" SIGN(S) - POSTED AT THERMOSTAT(S)

THIS HEATER MUST BE ELECTRICALLY GOUNDED

13. FIELD CONVERSION OF FUEL GAS: HE+ SERIES TWO-STAGE BURNERS

Tube Heater Burners are factory produced and supplied to operate on natural gas.

A field conversion kit is available from Rinnai and must be used to convert from natural gas to propane gas, or vice versa. Each kit contains the required parts and specific instructions to make the gas conversion.

Refer to the table below for kit part numbers.

NOTE: All Kits include a Gas Orifice*, and Valve Conversion Kit with Pressure Regulator Spring and Cap, and instructions to convert the gas valve and install the kit.

* Gas Orifice in the Field Conversion Kit:

- USA: 0 to 2,000 ft
- Refer to “High Altitude” section for altitudes higher than listed above

**** Call Factory for the Conversion Kit Part Number ****

14. HIGH ALTITUDE INSTALLATIONS - Refer to chart below for Restrictions

When installed above the altitude stipulated below for USA, the input must be de-rated by 4% for each 1000 ft above the altitude listed. Refer to the tables below for orifice size and restrictions that apply to high altitude installation (including total system length restrictions). Check with your local utility regarding the gas supply and the de-rating of this appliance. Maintain gas supply pressure indicated in Section 4.

USA: The factory installed orifice for this appliance is approved for altitudes zero to 2000 feet above sea level.

14.A ORIFICE CONVERSION

Altitude Restrictions this Model:

1. Do not install at altitudes greater than 8,500 ft
2. Restrict the length of any model to the shortest tube length at altitudes greater than 4,500 ft

When this appliance is installed above the altitude stipulated in the Table below, the input must be de-rated by 4% for each 1000 ft of altitude. **If your local utility supplies gas with a de-rated heat content, no orifice change is required in the heater** . Check with your local utility regarding de-rating, and the following specifically for country of installation.

14. HIGH ALTITUDE INSTALLATION - ORIFICE TABLE ~ SEE NOTES ON PREVIOUS PAGE ~

RINNAI RECOMMENDED ORIFICES - ALTITUDE CONVERSION

| MODEL INPUT RATE (MBH) | FOR USE AT ALTITUDES ABOVE (FEET) | | | | | | | |
|------------------------------|-----------------------------------|-----------------|-----------------|-----------------|-----------------|-----------------|-----------------|-----------------|
| | Gas Orifice Drill Size / Part# | | | | | | | |
| | Supplied | USA | | | | | | |
| | 0 | 2000 | 3000 | 4000 | 5000 | 6000 | 7000 | 8000 |
| 50 NG | #29 906000087 | 30 906000095 | 30 906000095 | 30 906000095 | 31 906000070 | 31 906000070 | 32 906000202 | 32 906000202 |
| 50 LPG | #46 906000088 | 46 906000088 | 47 906000212 | 47 906000212 | 47 906000212 | 48 906000213 | 48 906000213 | 49 906000071 |
| 65 NG | #23 906000089 | 25 906000197 | 25 906000197 | 25 906000197 | 27 906000198 | 27 906000198 | 29 906000087 | 29 906000199 |
| 65 LPG | #41 906000090 | 42 906000209 | 42 906000209 | 42 906000209 | 43 906000210 | 43 906000210 | 44 906000211 | 44 906000211 |
| 80 NG | #17 906000091 | 18 906000101 | 18 906000101 | 18 906000101 | 20 906000193 | 22 906000195 | 22 906000195 | 24 906000196 |
| 80 LPG | #37 906000092 | 38 906000206 | 38 906000206 | 39 906000207 | 40 906000208 | 40 906000208 | 42 906000209 | 42 906000209 |
| 115 NG | #2 906000093 | 3 906000172 | 3 906000172 | 5 906000173 | 6 906000174 | 8 906000176 | 8 906000176 | 10 906000188 |
| 115 LPG | #31 906000070 | 32 906000202 | 32 906000202 | 32 906000202 | 34 906000204 | 34 906000204 | 36 906000205 | 36 906000205 |
| 130 NG | 1 906000094 | A 906000171 | A 906000171 | 2 906000093 | 4 906000124 | 4 906000124 | 7 906000175 | 7 906000175 |
| 130 LPG | #30 906000095 | 31 906000070 | 31 906000070 | 31 906000070 | 32 906000202 | 32 906000202 | 33 906000203 | 33 906000203 |
| 155 NG | G 906000096 | F 906000181 | F 906000181 | F 906000181 | D 906000180 | B 906000178 | B 906000178 | 1 906000094 |
| 155 LPG | #26 906000097 | 27 906000198 | 27 906000198 | 28 906000199 | 29 906000087 | 29 906000087 | 30 906000095 | 30 906000095 |
| 180 NG | M 906000098 | K 906000184 | K 906000184 | K 906000184 | J 906000183 | H 906000182 | H 906000182 | F 906000217 |
| 180 LPG | #21 906000099 | 23 906000089 | 23 906000089 | 25 906000197 | 26 906000097 | 26 906000097 | 27 906000198 | 27 906000198 |
| 205 NG | R 906000100 | P 906000102 | P 906000102 | P 906000102 | N 906000186 | N 906000186 | M 906000098 | M 906000098 |
| 205 LPG | 18 906000101 | 20 906000193 | 20 906000193 | 21 906000099 | 23 906000089 | 23 906000089 | 25 906000197 | 25 906000197 |
| 225 NG | P 906000102 | N 906000186 | N 906000186 | N 906000186 | M 906000098 | M 906000098 | L 906000185 | L 906000185 |
| 225 LPG | #16 906000190 | 18 906000191 | 18 906000191 | 18 906000191 | 19 906000192 | 19 906000192 | 20 906000194 | 20 906000194 |
| 250 NG | R 906000100 | P 906000102 | P 906000102 | P 906000102 | O 906000187 | O 906000187 | N 906000186 | N 906000186 |
| 250 LPG | #14 906000104 | 16 906000103 | 17 906000091 | 17 906000091 | 18 906000101 | 19 906000128 | 19 906000128 | 19 906000128 |

15. REPLACEMENT PARTS: BURNER (Single-Stage and Two-Stage)

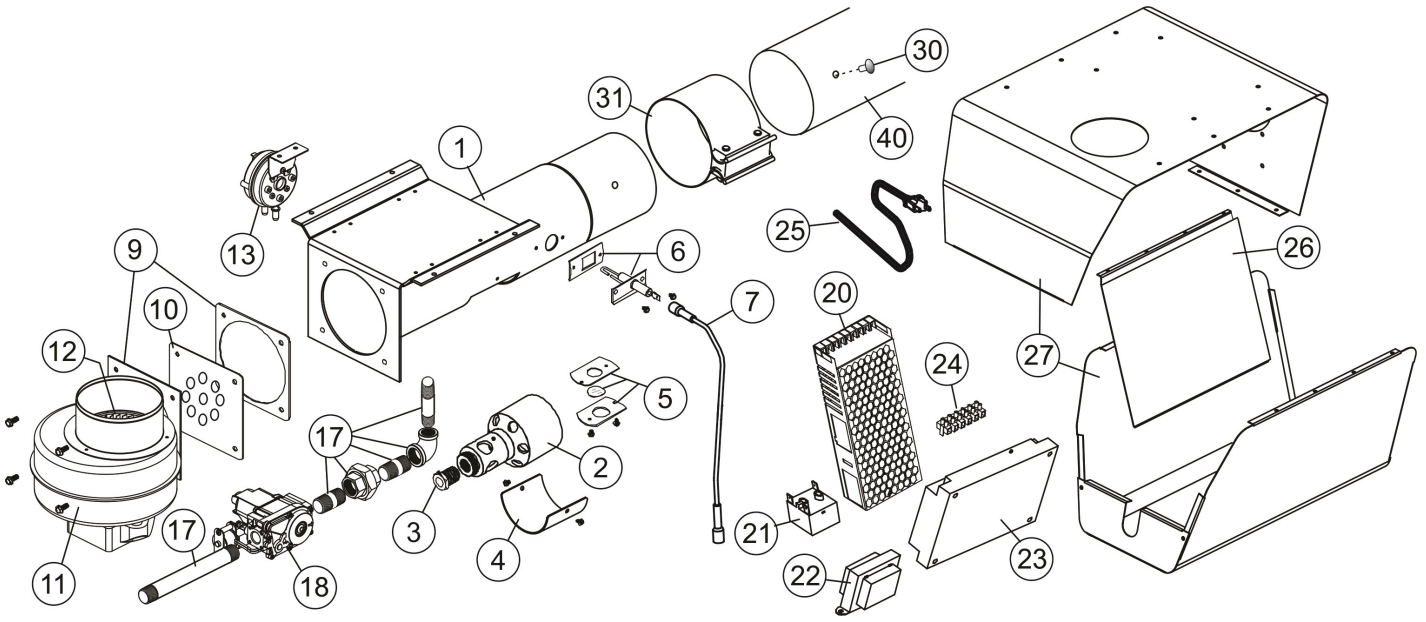

| # | PART DESCRIPTION | MODEL (BTU) | GAS TYPE | PART # | PART DESCRIPTION PRIMARY |
|---|-----------------------|-------------|-------------|-----------|--|
| 1 | BURNER CHAMBER | ALL | NG; Propane | 906000085 | SSTM Burner Chamber |
| 2 | BURNER CUP | ALL | NG; Propane | 906000086 | SSTM Burner Cup - Steel |
| 3 | MAIN BURNER ORIFICE | 50 | NG | 906000087 | Gas orifice low intensity heater: 29 Number Size |
| | | | Propane | 906000088 | Gas orifice low intensity heater: 46 Number Size |
| | | 65 | NG | 906000089 | Gas orifice low intensity heater: 23 Number Size |
| | | | Propane | 906000090 | Gas orifice low intensity heater: 41 Number Size |
| | | 80 | NG | 906000091 | Gas orifice low intensity heater: 17 Number Size |
| | | | Propane | 906000092 | Gas orifice low intensity heater: 37 Number Size |
| | | 115 | NG | 906000093 | Gas orifice low intensity heater: 2 Number Size |
| | | | Propane | 906000070 | Gas orifice low intensity heater: 31 Number Size |
| | | 130 | NG | 906000094 | Gas orifice low intensity heater: 1 Number Size |
| | | | Propane | 906000095 | Gas orifice low intensity heater: 30 Number Size |
| | | 155 | NG | 906000096 | Gas orifice low intensity heater: G Letter Size |
| | | | Propane | 906000097 | Gas orifice low intensity heater: 26 Number Size |
| | | 180 | NG | 906000098 | Gas orifice low intensity heater: M Letter Size |
| | | | Propane | 906000099 | Gas orifice low intensity heater: 21 Number Size |
| | | 205 | NG | 906000100 | Gas orifice low intensity heater: R Letter Size |
| | | | Propane | 906000101 | Gas orifice low intensity heater: 18 Number Size |
| | | 225 | NG | 906000102 | Gas orifice low intensity heater: P Letter Size |
| | | | Propane | 906000103 | Gas orifice low intensity heater: 16 Number Size |
| | | 250 | NG | 906000100 | Gas orifice low intensity heater: R Letter Size |
| | | | Propane | 906000104 | Gas orifice low intensity heater: 14 Number Size |
| 4 | BURNER CUP ACCESS CAP | ALL | | 906000105 | Removable cap to access burner cup and orifice |
| 5 | SIGHT GLASS ASSEMBLY | ALL | | 909000118 | Sight glass assembly - tube heater |
| 6 | IGNITER KIT | ALL | | 906000082 | Igniter & gasket kit / DSI tube heater |
| 7 | IGNITION CABLE | ALL | | 905000050 | Hi Voltage Wire-STW 2 x 1/4" Female Spade |
| 9 | BLOWER GASKET | ALL | Each | 906000106 | SST Blower Gasket |

| # | PART DESCRIPTION | MODEL (BTU) | MODEL DASH #/ GAS TYPE | PART # | PART DESCRIPTION PRIMARY |
|----|-----------------------------------|-------------|---------------------------|-------------------|---|
| 10 | EQUALIZER PLATE | 50 | NG; Propane | 906000107 | Outlet equalizer plate 50 |
| | | 65 & 80 | NG; Propane | 906000108 | Outlet equalizer plate 65 & 80 |
| | | 115 to 155 | NG; Propane | 906000109 | Outlet equalizer plate 115, 130 & 155 |
| | | 180 | NG; Propane | 906000110 | Outlet equalizer plate 180 |
| | | 205 | NG; Propane | 906000111 | Outlet equalizer plate 205 |
| | | 225 & 250 | NG; Propane | 906000109 | Outlet equalizer plate 225 & 250 |
| 11 | 24 VDC BLOWER ASSEMBLIES | 50 to 205 | NG; Propane | 908000014 | 24 VDC, 43W Blower Assembly - 50 to 205 |
| | | 225 & 250 | NG; Propane | 908000015 | 24 VDC, 63W Blower Assembly - 225 & 250 |
| 12 | BLOWER INTAKE RESTRICTOR | 50 & 65 | NG; Propane | 908000016 | Blower Air Intake Restrictor: 1.25 inch Hole |
| | | 130 | NG; Propane | 908000017 | Blower Air Intake Restrictor: 1.5 inch Hole |
| | | 80 & 115 | NG; Propane | 908000018 | Blower Air Intake Restrictor: 1.75 inch Hole |
| | | 155 | NG; Propane | 908000019 | Blower Air Intake Restrictor: 2.75 inch Hole |
| | | 180 & 205 | NG; Propane | 908000020 | Blower Air Intake Restrictor: 3.625 inch Hole |
| | | 225 & 250 | NG; Propane | 908000019 | Blower Air Intake Restrictor: 2.75 inch Hole |
| 13 | AIR PRESSURE SWITCH | 50 | NG; Propane | 905000029 | Air proving Switch 1.30" WC |
| | | 65 | NG; Propane | 905000030 | Air proving Switch 1.15" WC |
| | | 80 | NG; Propane | 905000031 | Air proving Switch 1.40" WC |
| | | 115 to 205 | NG; Propane | 905000032 | Air proving Switch 0.70" WC |
| | | 225 & 250 | NG; Propane | 905000030 | Air proving Switch 1.15" WC |
| 17 | GAS TRAIN PIPING | ALL | | Customer-Supplied | 1/2" x Pipe Nipples, Union and Elbow |
| 18 | GAS VALVE - SINGLE STAGE | 50 to 155 | NG | 906000078 | Valve gas comb 3.5" WC 24VAC VR8 NG |
| | | 50 to 155 | Propane | 906000079 | Valve gas comb 10" WC 24VAC VR8 LP |
| | | 180 to 250 | NG | 906000112 | Gas Valve - Slow Open 3.5" WC NG |
| | | 180 to 250 | Propane | 906000113 | Gas Valve - Slow Open 10" WC LP |
| | GAS VALVE - TWO-STAGE | ALL | NG Only | 906000114 | Gas Valve Two-stage- Slow Open -3.5"/2.2" (VR8205) |
| 20 | 120VAC to 24VDC POWER SUPPLY | 50 to 205 | NG; Propane | 905000033 | 120VAC to 24VDC Power Supply, 50 to 205 |
| | | 225 & 250 | NG; Propane | 905000034 | 120VAC to 24VDC Power Supply, 225 & 250 |
| 21 | RELAY SWITCH: 2-STAGE LO/HI INPUT | ALL | | 905000035 | Thermostat Relay- 24V |
| 22 | STEP DOWN TRANSFORMER | ALL | | 905000019 | Transformer 120/24V, 20VA AT120B1028 |
| 23 | FENWAL DSI CONTROL | ALL | | 905000020 | 3-Trial 24Vac with blower relay |
| 24 | TERMINAL BLOCK | ALL | Each | 905000018 | Terminal block (2) |
| 25 | ELECTRICAL CORD | ALL | | 905000028 | Cord - electrical 6' |
| 26 | COMPONENT PLATE | ALL | | 909000121 | Component mounting plate SST- Flat |
| 27 | BURNER HOUSING | ALL | | 906000115 | Burner housing coated black |
| 30 | STAINLESS STEEL RIVET 1/4" | ALL | Each | 906000116 | 1/4" Stainless Steel Rivet |
| 31 | COUPLER | ALL | | 906000117 | 4" swaged tube coupler torctite |

16. REPLACEMENT PARTS: TUBE SYSTEM HE+ SERIES

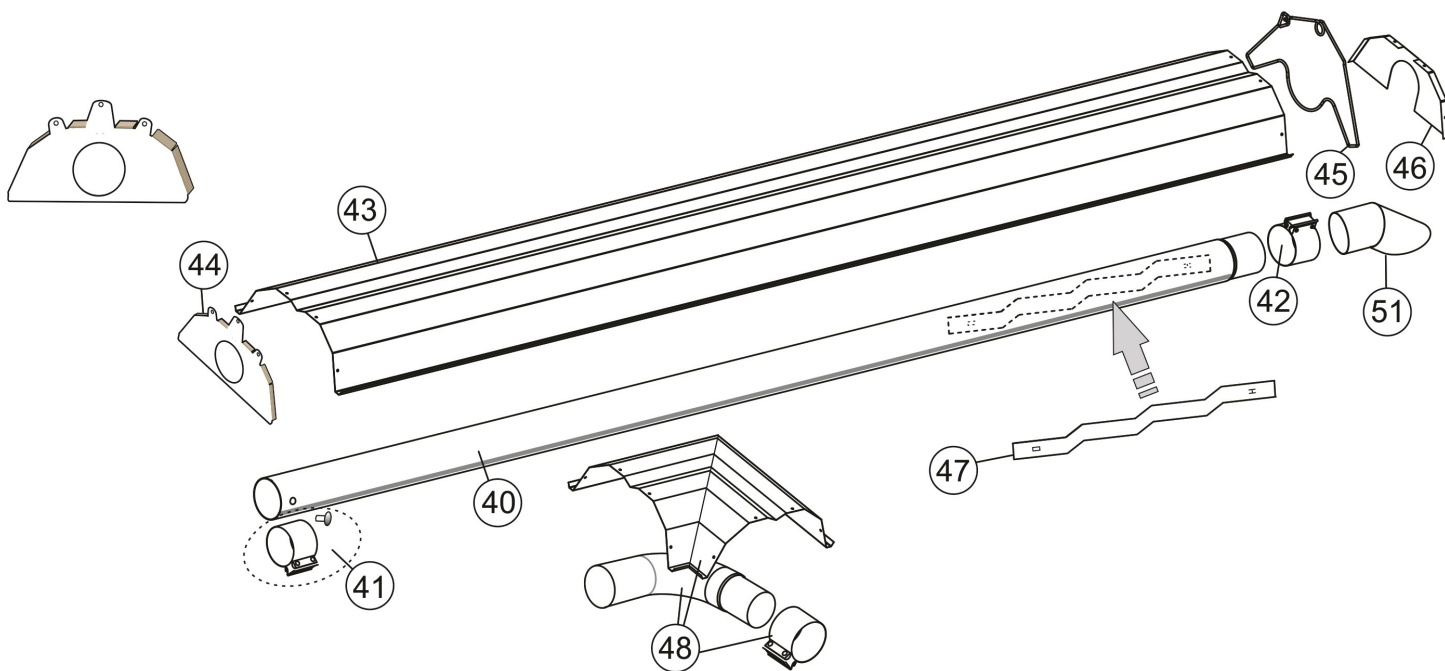

| # | PART DESCRIPTION | MODEL (BTU) | NOTE | PART # | PART DESCRIPTION PRIMARY |
|-----------|--|-------------|--|-----------|---|
| 40 | SYSTEM TUBES: | | | | |
| | PRIMARY COMBUSTION TUBE | 50 to 205 | | 906000118 | Aluminized Steel Tube with Holes + Rivet + Coupler |
| | | 225 to 250 | | 906000119 | Stainless Steel Tube with Holes + Rivet + Coupler |
| | HEAT EXCHANGER TUBES | ALL | | 906000120 | Coated Steel Tube; 10 ft with swage |
| | | 50 to 205 | Second Tube | 906000120 | Coated Steel Tube; 10 ft with swage |
| | | 225 to 250 | Second Tube | 906000119 | Stainless Steel Tube with Holes + Rivet + Coupler |
| 41 | STAINLESS STEEL COUPLER + STAINLESS STEEL RIVET | 225 to 250 | 1st to 2nd & 2nd to 3rd tube connections | 906000121 | Tube Connection Kit: Coupler + Rivet (225 to 250: 1st to 2nd & 2nd to 3rd tube) |
| 42 | COUPLER - Aluminized Steel | ALL | | 906000117 | 4" swaged tube coupler torcite |
| 43 | REFLECTOR | STRAIGHT | | 909000122 | Single Tube Reflector x 120" |
| 44 | PLATE HANGER - BURNER END ONLY | ALL | Burner End ONLY | 909000123 | Single Tube Plate Hanger (Burner End) |
| 45 | WIRE HANGER: TUBE / REFLECTOR | STRAIGHT | | 909000124 | Wire Hanger |
| 46 | REFLECTOR END CAP: SINGLE TUBE | STRAIGHT | Vent End ONLY | 909000125 | Reflector end cap: Single tube |
| 47 | TURBULATOR | ALL | Refer to Table in Manual | 906000122 | Turbulator 2.25" x 36" |
| 48 | 90° ELBOW KIT | ALL | OPTIONAL | 906000123 | 90° elbow + Coupler + Reflector Cover |
| 51 | HORIZONTAL VENT TERMINATION | ALL | OPTIONAL | 902000002 | 4" horizontal wall vent terminal |

NOTES

NOTES

NOTES

Rinnai America Corporation

103 International Drive
Peachtree City, GA 30269
Tel. 1-800-621-9419
Web. www.rinnai.us
www.rinnai.ca

900000015
2/2021